

Date :	16.05.01	Sign: sa
Last rev:	12.05.09	Sign: tb
Doc. No:	K4-10/28aE	Sign: tb
Page 1 of 2		

Standard beam reinforcement for BSF 150/20, with 200 kN ultimate load

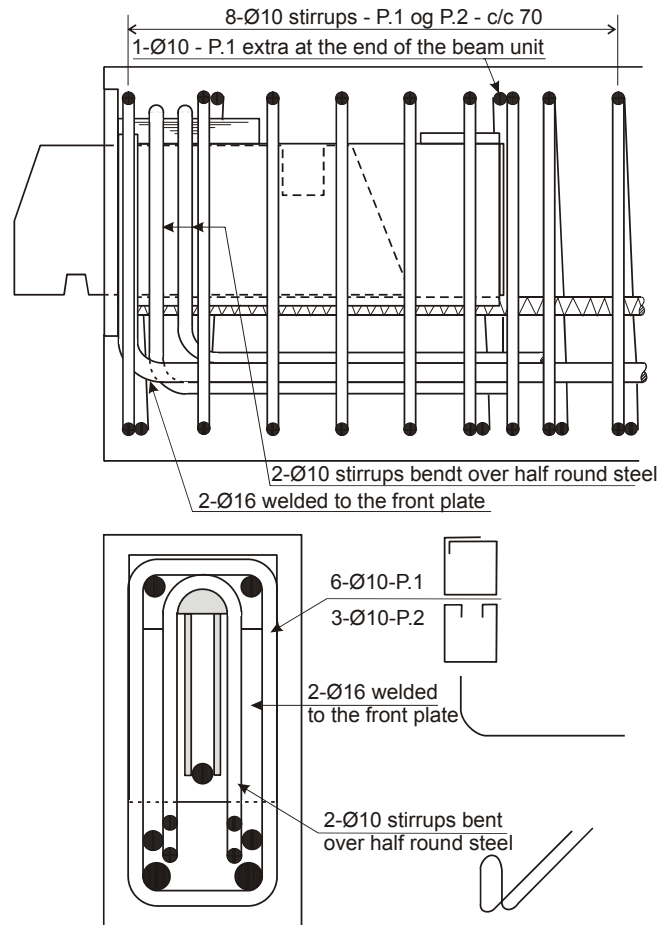

Figure 1 BSF 150/20, reinforcement in the beam end

The shown reinforcement are designed for the minimum beam size required to utilize the full capacity. See memo 2. Concrete grade is C45/55

H= height of beam and B= width of beam.

X= National demands for concrete cover.

Height of the reinforcement P4 is depended of the beam height “H” and the dimension of the main reinforcement.

The reinforcing bars P4 will have variable height. As shown in figure 1 the bars P4 will be located after one other, hence the vertical dimension of each bar have to be a little shorter than the previous bar (approximately 2x bar diameter).

Date :	16.05.01	Sign: sa
Last rev:	12.05.09	Sign: tb
Doc. No:	K4-10/28aE	Sign: tb
Page 2 of 2		

Standard beam reinforcement for BSF 150/20, with 200 kN ultimate load

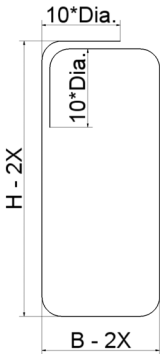
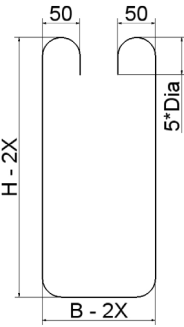
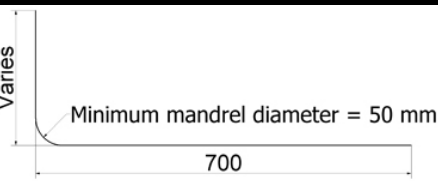
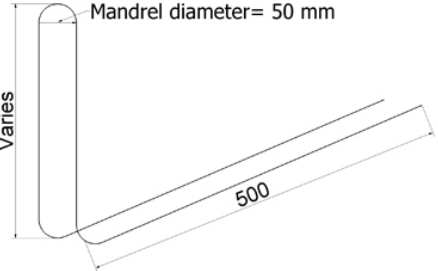
Pos.	Dia.	Cutting length.	No.pr. unit	Bar Schedule	Grade.
P1	Ø10		6		B500C
P2	Ø10		3		B500C
P3	Ø16		2		B500C
P4	Ø10		2		B500C