

| | | |
|--------------|------------|----------|
| Date : | 06.01.94 | Sign: tb |
| Last rev: | 24.09.09 | Sign: tb |
| Doc. No: | K4-10/22fE | Sign: tb |
| Page 1 of 15 | | |

Reinforcement design for BSF 250/50

PART 1 – BASIC ASSUMPTIONS

1.1 GENERAL

In these calculations certain assumptions has been made about dimensions and qualities in the precast concrete elements that may not always be the case. Therefore the following calculations of anchorage of the units and the resulting reinforcement must be considered as an example to illustrate the calculation model.

In beams it must always be checked that the forces from the anchorage reinforcement can be transferred to the beam's main reinforcement. The recommended shear reinforcement (stirrups) includes all necessary stirrups in the beam end; i.e. the normal shear reinforcement in beam ends and an addition due to the cantilever action of the beam unit from the beam.

The information found here and in the memos assumes that the design of the elements and the use of the units in structural elements are carried out under the supervision of a structural engineer with knowledge about the behavior of concrete structures.

1.2 STANDARDS

The calculations are carried out according to:

Eurocode 2: Design of concrete structures. Part 1-1. General rules and rules for buildings.

Eurocode 3: Design of steel structures. Part 1-1: General rules and rules for buildings.

Eurocode 3: Design of steel structures. Part 1-8: Design of joints.

EN 10080: Steel for the reinforcement of concrete. Weldable reinforcing steel. General.

For all NPDs in the Eurocodes the recommended values are used.

These NDPs are: In EC 2: γ_c ; γ_s ; α_{cc} ; α_{ct} ; k_1 ; k_2 and $\emptyset_{m,min}$. In EC 3: γ_{M0} ; γ_{M1} and γ_{M2} .

1.3 LOADS

Vertical ultimate limit state load = $F_V = 950$ kN

Horizontal ultimate limit state load = $F_H = 0,3 \times F_V = 285$ kN

The design is carried out with a horizontal force of 30 % of the vertical force. Recommended capacity for transfer of active forces (as wind loads) may be assumed to be 20 % of smallest vertical load present at the same time.

| | | |
|--------------|------------|----------|
| Date : | 06.01.94 | Sign: tb |
| Last rev: | 24.09.09 | Sign: tb |
| Doc. No: | K4-10/22fE | Sign: tb |
| Page 2 of 15 | | |

Reinforcement design for BSF 250/50

1.4 QUALITIES

Concrete grade C45/55: $f_{cd} = \alpha_{cc} \cdot f_{ck} / \gamma_c = 1,0 \cdot 45 / 1,5 = 30,0 \text{ MPa}$

$$f_{ctd} = \alpha_{ct} \cdot f_{ctk,0,05} / \gamma_c = 1,0 \cdot 2,70 / 1,5 = 1,80 \text{ MPa}$$

$$f_{bd} = 2,25 \cdot \eta_1 \cdot \eta_2 \cdot f_{ctd} = 2,25 \cdot 1,0 \cdot 1,0 \cdot 1,80 = 4,05 \text{ MPa}$$

Reinforcement B500C: $f_{yd} = f_{yk} / \gamma_s = 500 / 1,15 = 435 \text{ MPa}$

Tension in threaded bars: 8.8 quality steel: $f_{yd} = f_y / \gamma_{M2} = 640 / 1,25 = 512 \text{ MPa}$

Structural steel S355:

$$f_{yd} = f_y / \gamma_{M0} = 355 / 1,00 = 355 \text{ MPa} < f_u / \gamma_{M2} = 510 / 1,25 = 408 \text{ MPa}$$

Shear: $f_{sd} = f_y / (\gamma_{M0} \cdot \sqrt{3}) = 355 / (1,00 \cdot \sqrt{3}) = 205 \text{ MPa}$

$$\text{Welds: } f_{vw,d} = \frac{f_u}{\gamma_{M2} \sqrt{3}} \times \frac{1}{\beta_w} = \frac{510}{1,25 \times \sqrt{3}} \times \frac{1}{0,9} = 262 \text{ MPa}$$

Half round steel S275 N/NL:

$$f_{yd} = f_y / \gamma_{M0} = 275 / 1,00 = 275 \text{ MPa} < f_u / \gamma_{M2} = 430 / 1,25 = 344 \text{ MPa}$$

$$\text{Welds: } f_{w,d} = \frac{f_u}{\gamma_{M2} \sqrt{3}} \times \frac{1}{\beta_w} = \frac{430}{1,25 \times \sqrt{3}} \times \frac{1}{0,85} = 233 \text{ MPa}$$

Reinforcement design for BSF 250/50

DEL 2 – ANCHORAGE OF THE UNITS

2.1 BEAM UNIT - EQUILIBRIUM

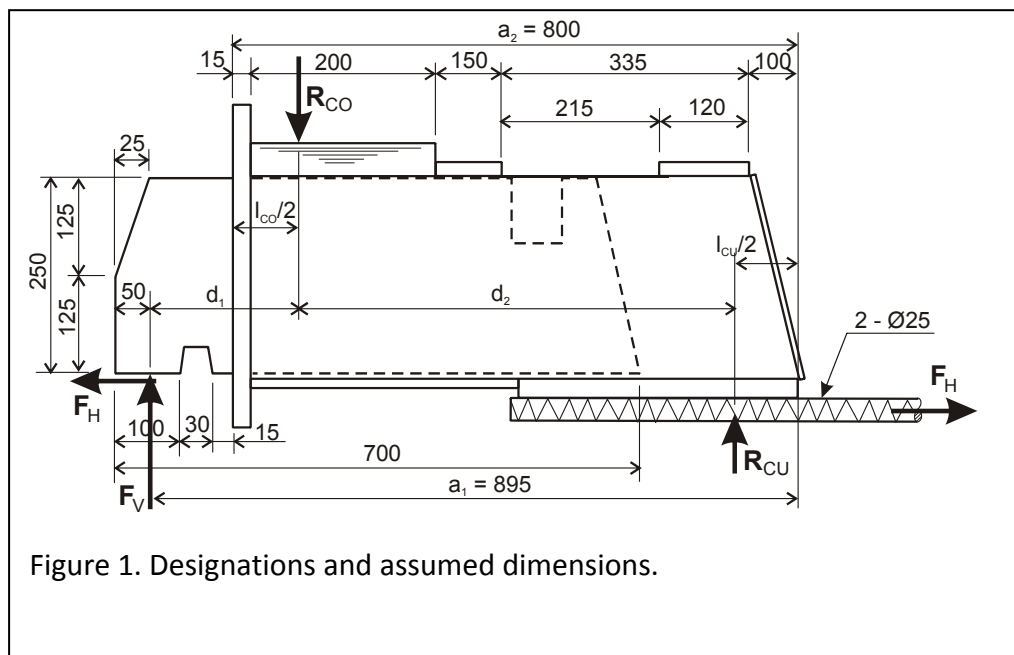

Neglecting the moment created by the small vertical shift in the transfer of F_H .

$$R_{CU} = F_V \times d_1 / d_2$$

$$R_{CO} = F_V + R_{CU}$$

$$f_{cd} = f_{ct} / \gamma_c$$

$$l_{CU} = R_{CU} / (f_{cd} \times b) \quad (b \text{ is the width of the beam unit} = 100 \text{ mm.})$$

$l_{CO}/2$ is decided by the location of the front reinforcement. Assume 2-Ø20 welded to the front plate plus 4-Ø20 bent over the half round steel:

$$l_{CO}/2 = \frac{314 \times (27 + 27 + 67 + 107 + 147)}{5 \times 314} = 75 \text{ mm}$$

$$d_1 = a_1 - a_2 + l_{CO}/2$$

$$d_2 = a_2 - l_{CO}/2 - l_{CU}/2$$

Reinforcement design for BSF 250/50

Use a spread sheet. Assume d_1/d_2 , calculate resulting d_1/d_2 . Change assumed value until they are equal. (Spread sheet "Equilibrium-BSF250-50-beamunit.xls".)

| Equilibrium of BSF250/50 beam unit: | |
|-------------------------------------|--|
| Concrete grade = B 45/55 | |
| Geometry: | Material coefficient for concrete = 1,5 |
| $a_1 =$ | 895 mm $f_{cd} = 30,0$ MPa |
| $a_2 =$ | 800 mm |
| Width of beam unit = | 100 mm $F_V = 950$ kN |
| $l_{CO}/2 =$ | 75 mm |
| Assumed $d_1 / d_2 = 0,2479043$ | |
| $R_{CU} =$ | 236 kN $d_1 = 170$ mm |
| $R_{CO} =$ | 1186 kN $d_2 = 686$ mm |
| $l_{CU} =$ | 79 mm |
| Calculated $d_1 / d_2 = 0,2479043$ | |

| | | |
|--------------|------------|----------|
| Date : | 06.01.94 | Sign: tb |
| Last rev: | 24.09.09 | Sign: tb |
| Doc. No: | K4-10/22fE | Sign: tb |
| Page 5 of 15 | | |

Reinforcement design for BSF 250/50

2.2 BEAM UNIT – ANCHORAGE IN FRONT

2.2.1 Check of capacity

$$A_{s, \text{nodv}} = R_{CO} / f_{sd, \text{arm}} = 1186 / 0,435 = 2726 \text{ mm}^2$$

$$\text{Assumed } 2\text{-}\varnothing 20 + 4\text{-}\varnothing 20 = 2 \times 314 + 2 \times 4 \times 314 = 3140 \text{ mm}^2 > 2726 \text{ mm}^2 - \text{ok}$$

$$\sigma_s = 1186 \times 10^3 / 3140 = 378 \text{ MPa}$$

2.2.2 Anchorage

As illustrated in figure 2 the reinforcement will be very congested when the beam has minimum dimensions. This must be taken into consideration when calculating the anchorage length (the horizontal part of the front reinforcement). Since the reinforcing bars are so close together this may necessitate considering them as bundled bars. (The main reinforcement in the beam is not shown on the side view.)

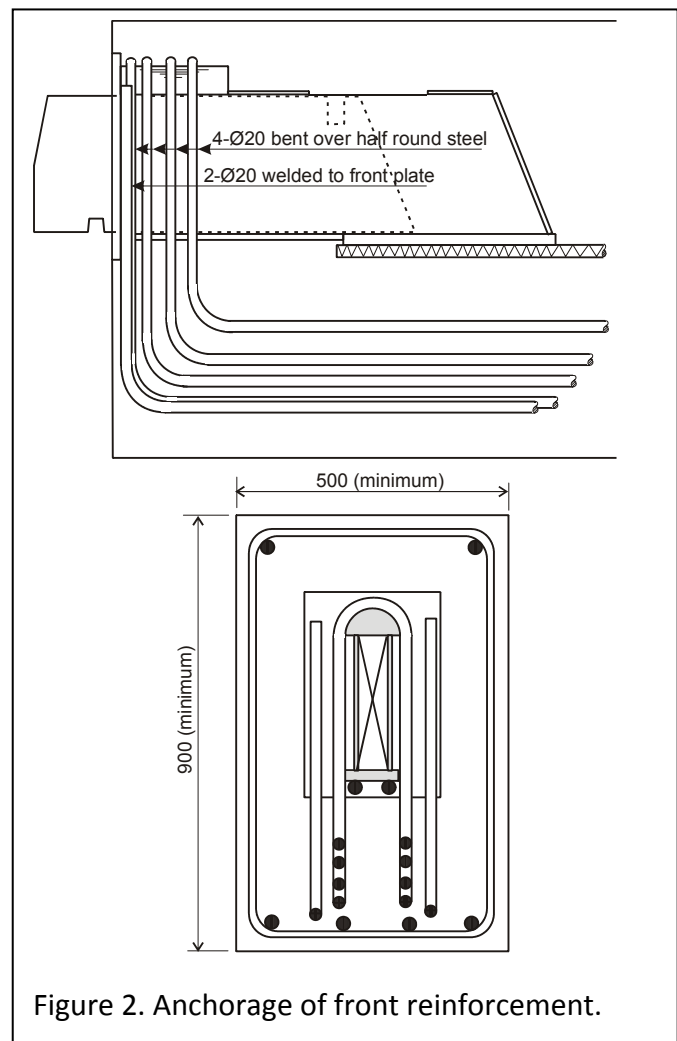

| | | |
|--------------|------------|----------|
| Date : | 06.01.94 | Sign: tb |
| Last rev: | 24.09.09 | Sign: tb |
| Doc. No: | K4-10/22fE | Sign: tb |
| Page 6 of 15 | | |

Reinforcement design for BSF 250/50

According to EC2 clauses 8.4.3 and 8.4.4:

$$l_{bd} = \alpha_1 \cdot \alpha_2 \cdot \alpha_3 \cdot \alpha_4 \cdot \alpha_5 \cdot l_{b,reqd} \geq l_{b,min}$$

$$l_{b,reqd} = \frac{\sigma_{sd}}{f_{bd}} \cdot \frac{\sigma_{sd}}{f_{bd}} = \frac{20}{4} \cdot \frac{378}{4,05} = 466 \text{ mm}$$

$$l_{b,min} = \max(0,3 \cdot l_{b,reqd}; 10 \cdot \emptyset; 100 \text{ mm})$$

$$l_{b,min} = 200 \text{ mm}$$

Straight bar: $\alpha_1 = 1,0$

Concrete cover:

$$c_d = \min(a/2; c_1; c)$$

$$c_d = \min(20/2; 50; 40) = 10 \text{ mm}$$

$$\alpha_2 = 1 - 0,15 \cdot (c_d - 3 \cdot \emptyset) / \emptyset$$

$$\alpha_2 = 1 - 0,15 \cdot (10 - 3 \cdot 20) / 20 > 1,0$$

$$\alpha_2 = 1,0$$

Confinement by reinforcement: Assume transverse reinforcement $\emptyset 12$ -c/c150 mm:

$$\alpha_3 = 1 - K \cdot \lambda = 1 - 0,05 \cdot \frac{113 \cdot \frac{400}{150} - 0,25 \cdot 314}{314} = 0,96$$

Confinement by welded transverse reinforcement: $\alpha_4 = 1,0$

Confinement by transverse pressure: $\alpha_5 = 1,0$

$$l_{bd} = 1,0 \cdot 1,0 \cdot 0,96 \cdot 1,0 \cdot 1,0 \cdot 466 = 448 \text{ mm}$$

It must always be checked that the beam's main reinforcement has sufficient anchorage at the end of the horizontal part of the front anchorage. This will probably lead to greater lengths for the horizontal part of the front anchorage than calculated here.

| | | |
|--------------|------------|----------|
| Date : | 06.01.94 | Sign: tb |
| Last rev: | 24.09.09 | Sign: tb |
| Doc. No: | K4-10/22fE | Sign: tb |
| Page 7 of 15 | | |

Reinforcement design for BSF 250/50

The force is approximately

$[F_V \times \frac{a}{z} + \frac{F_V}{2} + F_H \frac{x_1}{z}]$. Additional force in the beam's top reinforcement is about $[F_H \cdot \frac{x_2}{z}]$, but this force leads to a reduction in the compressive stresses and may be neglected. If there is a large distance between the horizontal part of the front anchorage and the beam's main reinforcement, the length of the horizontal part of the front anchorage must be increased with this distance. (This distance is very small in the figure.)

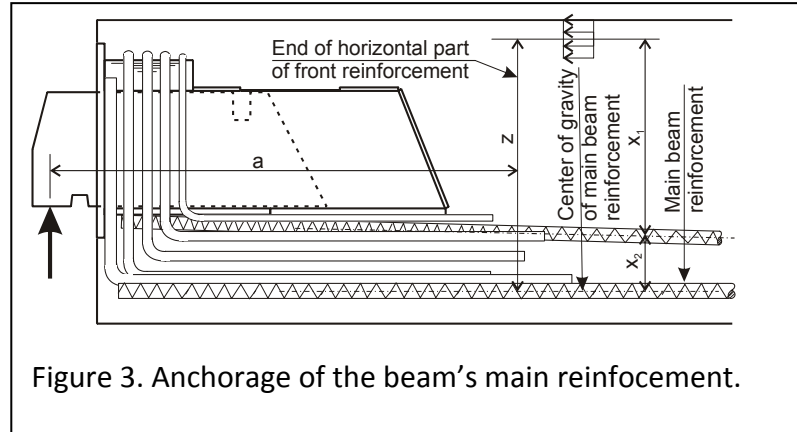

Figure 3. Anchorage of the beam's main reinforcement.

2.2.3 Bending of front reinforcement and requirements for transverse reinforcement

See figure 4. Stress in the anchorage reinforcement is 379 MPa.

According to EN 1992-1-1, clause 8.3:

$\varnothing_{m,min}$ is generally $7 \cdot 20 = 140$ mm to avoid damage to the reinforcing bars.

To avoid cross bars:

$$\varnothing_{m,min} = \frac{F_{bt} \cdot (\frac{1}{a_b} + \frac{1}{2} \cdot \varnothing)}{f_{cd}}$$

Ø20 bars bent over half round steel:

$$\varnothing_{m,min} = \frac{1186 \cdot 10^3}{30} \cdot \left(\frac{1}{120} + \frac{1}{2 \cdot 20} \right) = 1305 \text{ mm}$$

Ø20 bars welded to front plate:

$$\varnothing_{m,min} = \frac{1186 \cdot 10^3}{30} \cdot \left(\frac{1}{220} + \frac{1}{2 \cdot 20} \right) = 1186 \text{ mm}$$

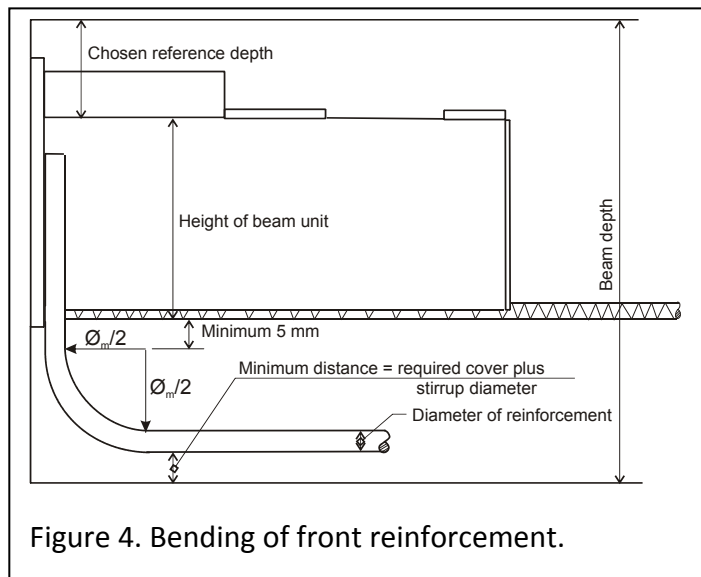

Figure 4. Bending of front reinforcement.

| | | |
|--------------|------------|----------|
| Date : | 06.01.94 | Sign: tb |
| Last rev: | 24.09.09 | Sign: tb |
| Doc. No: | K4-10/22fE | Sign: tb |
| Page 8 of 15 | | |

Reinforcement design for BSF 250/50

If cross bars are required the total area of this reinforcement shall be at least 40% of the area of the bent bars. (This last requirement is from the Norwegian concrete design code, as EC2 does not contain any particular requirements for such reinforcement.) It is the opinion of this structural engineer that it may be reduced according to the stress in the anchorage reinforcement. The cross bars shall consist of at least two bars placed inside the bend. The cross bars can be anchored with 90° hook at the ends or by being shaped like a U-bar.

| Bar diameter | Mandrel diameter | Transverse reinforcement |
|--------------|----------------------|--------------------------|
| 20 | ≥ 1305 mm | Not required |
| | < 1305 mm; ; ≥ 140mm | Required |

Assumed concrete grade is C45/55. For other concrete grades and bar diameters the mandrel diameters will be different.

| | | |
|--------------|------------|----------|
| Date : | 06.01.94 | Sign: tb |
| Last rev: | 24.09.09 | Sign: tb |
| Doc. No: | K4-10/22fE | Sign: tb |
| Page 9 of 15 | | |

Reinforcement design for BSF 250/50

2.2.4 Minimum beam depth

See figure 4 and Memo 10.

The recommended reference depth is 80 mm and the height of the beam unit is 225 mm. Assume that Ø12 will require 15 mm space, and assume 25 mm concrete cover. Also assume that a 20 mm bar requires 22 mm space.

To avoid cross bars the minimum beam depth will be $80+225+5+(1305/2)+15+22+25 = 1025 \text{ mm} \approx 1000 \text{ mm}$.

Accepting cross bars the minimum beam depth will be $80+225+5+(140/2)+22+15+25 = 442 \text{ mm} \approx 450 \text{ mm}$.

However, with the horizontal part of the front anchorage so close to the bottom of the beam unit, the unit and the bars may be torn out as one piece. Therefore a minimum beam depth of 900 mm is recommended.

If cross bars are required: $0,4 \cdot 3140 \cdot 379 / 435 = 1094 \text{ mm}^2$

If U-shaped bars are used they will be properly anchored in one end only. Hence the total reinforcement area must be twice of the calculated area. Each bar has two legs:

Select two Ø12 U-shaped stirrups inserted from each side:

$$5 \cdot 2 \cdot 112 \cdot 2 = 2240 \text{ mm}^2 > 1094 \cdot 2 = 2188 \text{ mm}^2.$$

2.3 BEAM UNIT – ANCHORAGE OF HORIZONTAL FORCES

2.3.1 Check of capacity

$$F_H = 285 \text{ kN (see clause 1.3)}$$

$$A_{s, \text{reqd}} = 285 / 0,435 = 655 \text{ mm}^2$$

Assumed 2-Ø25 = 982 mm² - ok

| | | |
|---------------|------------|----------|
| Date : | 06.01.94 | Sign: tb |
| Last rev: | 24.09.09 | Sign: tb |
| Doc. No: | K4-10/22fE | Sign: tb |
| Page 10 of 15 | | |

Reinforcement design for BSF 250/50

2.3.2 Anchorage length

According to EC2 clause 8.4.4:

$$l_{bd} = \alpha_1 \cdot \alpha_2 \cdot \alpha_3 \cdot \alpha_4 \cdot \alpha_5 \cdot l_{b,reqd} \geq l_{b,min}$$

$$l_{b,reqd} = \frac{\sigma}{4} \cdot \frac{\sigma_{sd}}{f_{bd}} = \frac{25}{4} \cdot \frac{285/0,982}{4,05} = 448 \text{ mm}$$

$$l_{b,min} = \max(0,3 \cdot l_{b,reqd}; 10 \cdot \emptyset; 100 \text{ mm}) = 250 \text{ mm}$$

Straight bar: $\alpha_1 = 1,0$

Concrete cover:

$$c_d = \min(a/2; c_1; c) = \min(102/2; 50; 40) = 51 \text{ mm}$$

$$\alpha_2 = 1 - 0,15 \cdot (c_d - 3 \cdot \emptyset) / \emptyset = 1 - 0,15 \cdot (51 - 3 \cdot 25) / 25 > 1,0 ; \text{ i.e.: } \alpha_2 = 1,0$$

Confinement by reinforcement: Assume transverse reinforcement $\emptyset 12\text{-c}/c150 \text{ mm}$

$$\alpha_3 = 1 - K \cdot \lambda = 1 - 0,05 \cdot \frac{113 \cdot \frac{400}{150} - 0,25 \cdot 491}{491} = 0,98$$

Confinement by welded transverse reinforcement: $\alpha_4 = 1,0$

Confinement by transverse pressure: $\alpha_5 = 1,0$

$$l_{bd} = 1,0 \cdot 1,0 \cdot 0,98 \cdot 1,0 \cdot 1,0 \cdot 448 = 439 \text{ mm}$$

| | | |
|---------------|------------|----------|
| Date : | 06.01.94 | Sign: tb |
| Last rev: | 24.09.09 | Sign: tb |
| Doc. No: | K4-10/22fE | Sign: tb |
| Page 11 of 15 | | |

Reinforcement design for BSF 250/50

2.4 COLUMN UNIT – ANCHORAGE IN THE COLUMN

2.4.1 Check of capacity

$$M = F_H \times (25 + 25/2) + F_V \times \{[(170 + 12)/2] - 73,5\} = 950 \times (0,3 \times 37,5 + 19) = 28738 \text{ kNm}$$

$$S = 28738 / 315 = 91,2 \text{ kN}$$

$$A_s = 91,2 / 0,435 = 210 \text{ mm}^2$$

$$1 - \text{Ø}20 = 314 \text{ mm}^2 \text{ at top - ok.}$$

$$F_H - S = 0,3 \times 950 - 91 = 194 \text{ kN}$$

$$A_s = 194 / 0,435 = 446 \text{ mm}^2$$

2-Ø20 or 1-Ø25 at the bottom is sufficient.

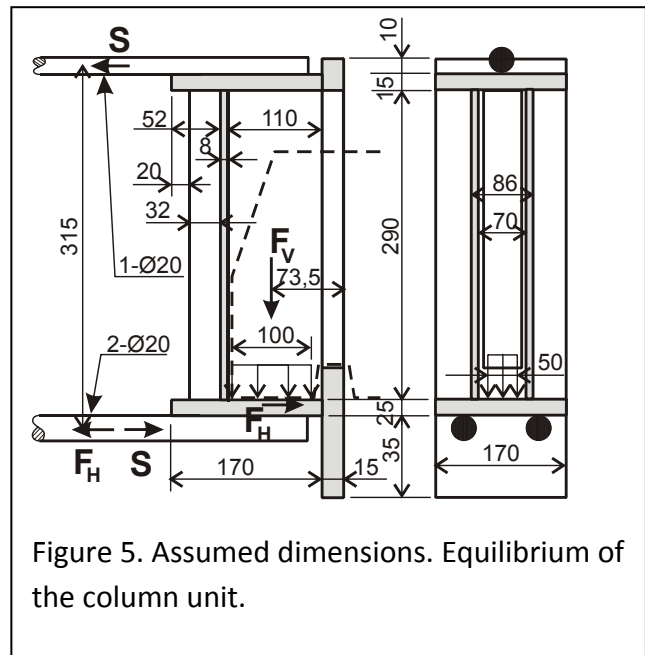

| | | |
|---------------|------------|----------|
| Date : | 06.01.94 | Sign: tb |
| Last rev: | 24.09.09 | Sign: tb |
| Doc. No: | K4-10/22fE | Sign: tb |
| Page 12 of 15 | | |

Reinforcement design for BSF 250/50

2.4.2 Anchorage of welded reinforcement

Normally there are similar units on opposite sides of the column. The easiest anchorage is then to connect the units as shown in Memo 43.

If anchorage bars bent up and down are used, the amount of reinforcement must be as calculated in clause 2.4.1.

If U-shaped bars are used the area of the reinforcing bar may be half of that calculated in clause 2.4.1, because two sections are providing the anchorage. It will improve the anchorage considerably if a bar is placed in the bend of the U-shaped bars.

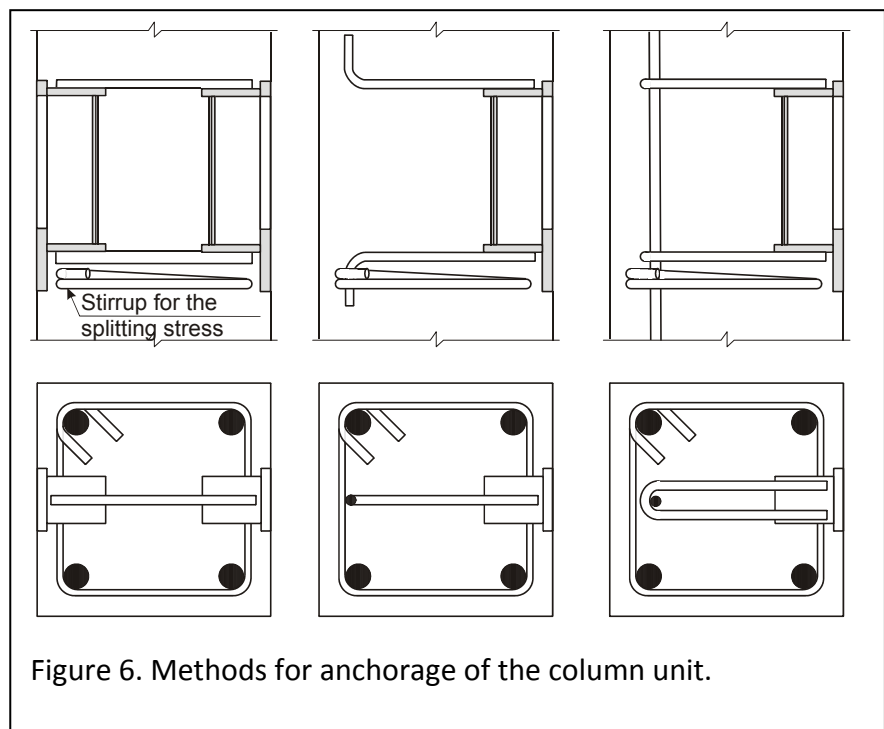

Figure 6. Methods for anchorage of the column unit.

Necessary welding of reinforcing bars is shown in clause 2.5.

The stirrups for the splitting stress is calculated in clause 3.4.

| | | |
|---------------|------------|----------|
| Date : | 06.01.94 | Sign: tb |
| Last rev: | 24.09.09 | Sign: tb |
| Doc. No: | K4-10/22fE | Sign: tb |
| Page 13 of 15 | | |

Reinforcement design for BSF 250/50

2.5 WELDING OF REINFORCEMENT TO THE UNITS

Selecting to always weld for the capacity of the bar.

Assuming welds on both sides of the bar. Length of weld = l_w .

For reinforcing bar Ø16:

$$l_w \cdot a = (201 \cdot 0,435) / (0,262 \cdot 2) = 167 \text{ mm}^2$$

Select $a = 4 \text{ mm}$; i.e. $l_{w,\min} = 42 \text{ mm}$

For reinforcing bar Ø20:

$$l_w \cdot a = (314 \cdot 0,435) / (0,262 \cdot 2) = 261 \text{ mm}^2$$

Select $a = 5 \text{ mm}$; i.e. $l_{w,\min} = 52 \text{ mm}$

For reinforcing bar Ø25:

$$l_w \cdot a = (491 \cdot 0,435) / (0,262 \cdot 2) = 408 \text{ mm}^2$$

Select $a = 5 \text{ mm}$; i.e. $l_{w,\min} = 82 \text{ mm}$

For reinforcing bar Ø32:

$$l_w \cdot a = (804 \cdot 0,435) / (0,262 \cdot 2) = 667 \text{ mm}^2$$

Select $a = 6 \text{ mm}$; i.e. $l_{w,\min} = 111 \text{ mm}$

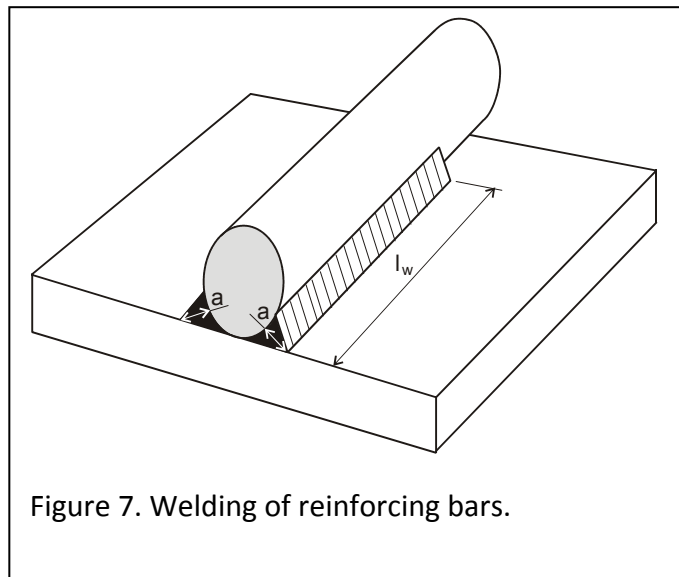

| | | |
|---------------|------------|----------|
| Date : | 06.01.94 | Sign: tb |
| Last rev: | 24.09.09 | Sign: tb |
| Doc. No: | K4-10/22fE | Sign: tb |
| Page 14 of 15 | | |

Reinforcement design for BSF 250/50

PART 3 – REINFORCEMENT

3.1 BEAM – REINFORCEMENT IN THE REAR

$$A_{s, \text{nodv}} = R_{CU} / f_{sd} = 236 / 0,435 = 543 \text{ mm}^2,$$

corresponding to $543 / (3 \times 2 \times 113) = 0,80$; i.e. 3 – Ø12 stirrups.

3.2 BEAM – SHEAR STIRRUPS

Use a strut-and-tie model with compressive diagonals at 45°.

The shear force within the central part of the beam unit is assumed to be $R_{CO} = 1186 \text{ kN}$.

Assume $z = 850 \text{ mm}$ and stirrup diameter Ø12.

$$s = A_{sw} \cdot z \cdot f_{yd} \cdot \cot \theta / V$$

$$s = 2 \times 113 \times 850 \times 435 \times \cot 45^\circ / 1186 \times 10^3 = 70 \text{ mm}$$

Select Ø12 c/c 55 mm.

This reinforcement should be brought approximately 200 mm past the end of the beam unit in order to absorb any splitting effects from the anchorage of reinforcement in the rear.

3.3 BEAM – CHECK OF SHEAR COMPRESSION

Assume beam width of 500 mm and beam depth of 800 mm. (See also clause 2.2.) This means that $z_{\text{min}} \approx 1000 - 50 - 100 = 850 \text{ mm}$ with one layer of reinforcement in the top of the beam and three layers in the bottom.

The shear reinforcement is calculated based on 45° compressive field. The check of shear compression will be carried out under the same assumption:

$$V_{Rd, \text{max}} = \alpha_{cw} \cdot b_w \cdot z \cdot v_1 \cdot f_{cd} / (\cot \theta + \tan \theta)$$

$$V_{Rd, \text{max}} = \{1,0 \cdot (500 - 100) \cdot 850 \cdot 0,6 \cdot [1 - (45/250)] \cdot 30,0 / (\cot 45^\circ + \tan 45^\circ)\} \cdot 10^{-3}$$

$$V_{Rd, \text{max}} = 2509 \text{ MPa} > 1189 \text{ MPa} - \text{OK}$$

3.4 COLUMN – SPLITTING STRESS

Splitting stress under the column unit according to Leonhardt $\approx 0,2 \times F_V = 0,2 \times 950 = 190 \text{ kN}$

$$A_S = 190 / 0,435 = 437 \text{ mm}^2$$

2-Ø12 stirrups ($2 \times 2 \times 113 \text{ mm}^2$) are sufficient.

| | | |
|---------------|------------|----------|
| Date : | 06.01.94 | Sign: tb |
| Last rev: | 24.09.09 | Sign: tb |
| Doc. No: | K4-10/22fE | Sign: tb |
| Page 15 of 15 | | |

Reinforcement design for BSF 250/50

3.5 CONCLUSION – REINFORCEMENT IN THE BEAM

For clarity the beam's main reinforcement is not shown in the side view. Between the shown stirrups in each end of the beam a normal calculation of the shear reinforcement must be carried out. The main reinforcement in the beam must of course also be calculated.

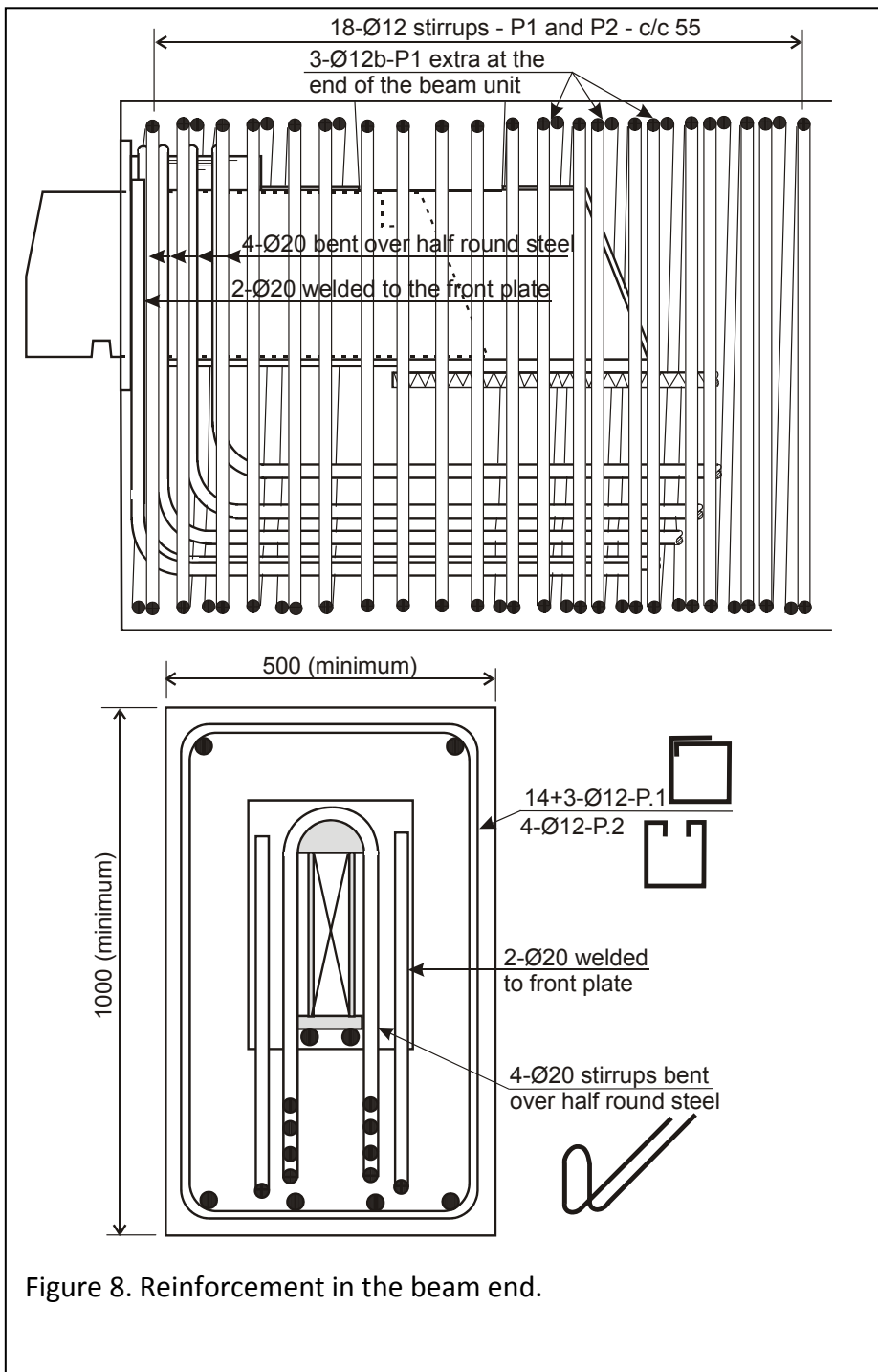

Figure 8. Reinforcement in the beam end.

At the end of the front anchorage it must be checked that the beam's main reinforcement has sufficient anchorage. See clause 2.2.4.