

Date:	26.04.2011	Sign: sss
Last Rev:	04.07.2011	Sign: sss
Doc. No:	K3-10/55dE	Control: ps
Page 1 of 8		

Recommended reinforcement pattern TSS 101

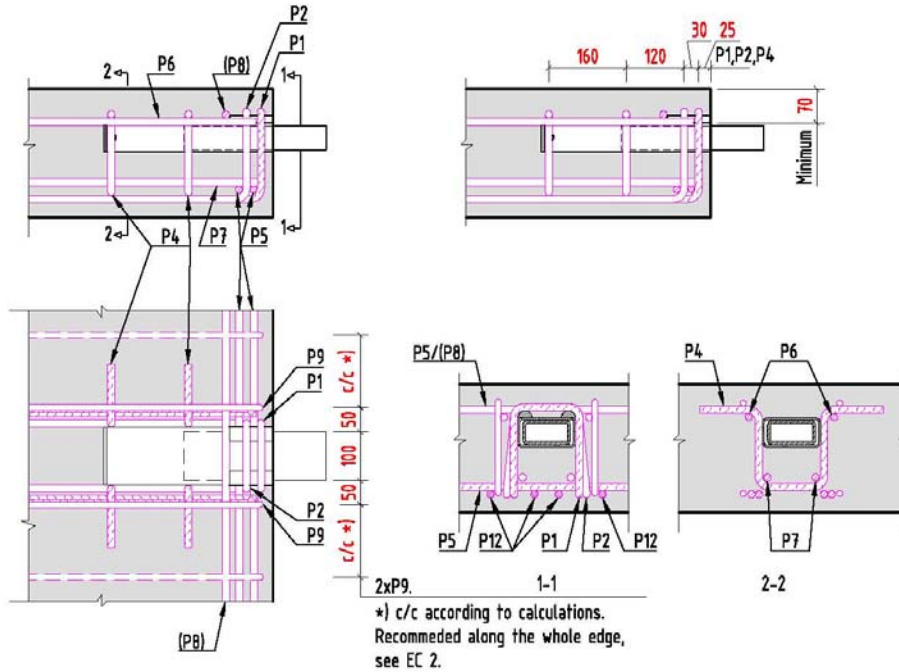

Figure 1: Recommended reinforcement pattern for TSS 101 units. Slab thickness $t=265\text{mm}$ and edge distance $k>450\text{mm}$. Slab thickness $t=200\text{mm}$ and edge distance $k>400\text{mm}$.

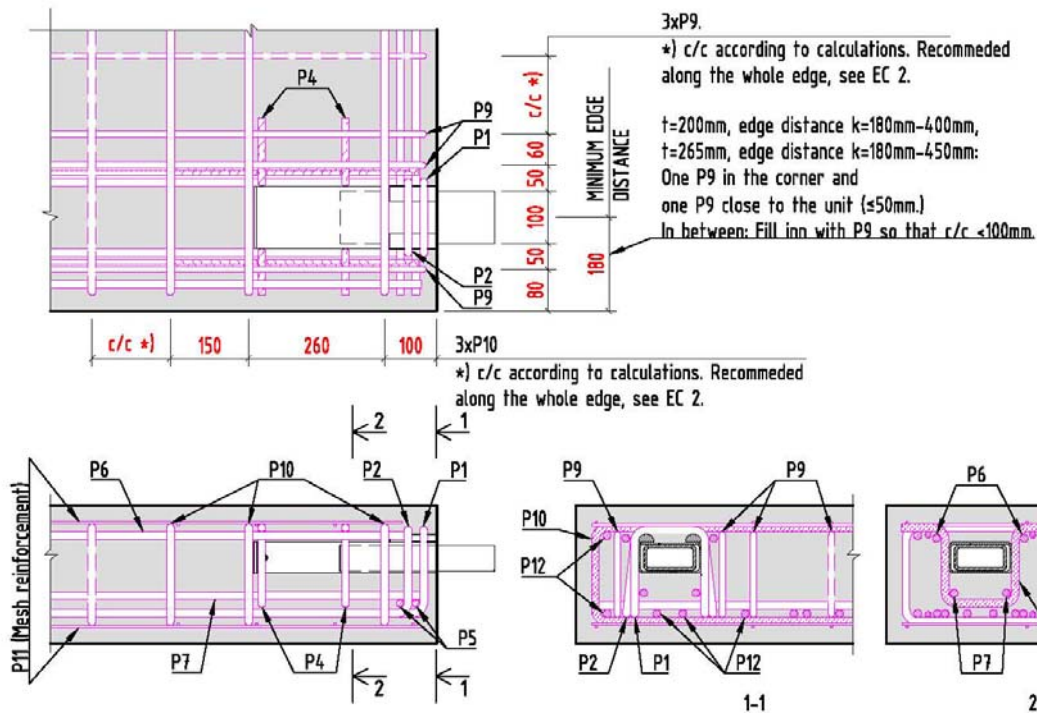

Figure 2: Recommended reinforcement pattern for TSS 101 units. Slab thickness $t=265\text{mm}$ and edge distance $180\text{mm} \leq k \leq 450\text{mm}$. Slab thickness $t=200\text{mm}$ and edge distance $180\text{mm} \leq k \leq 400\text{mm}$. Ultimate limit load according to Figure 5.

Date:	26.04.2011	Sign: sss
Last Rev:	04.07.2011	Sign: sss
Doc. No:	K3-10/55dE	Control: ps
Page 2 of 8		

Recommended reinforcement pattern TSS 101

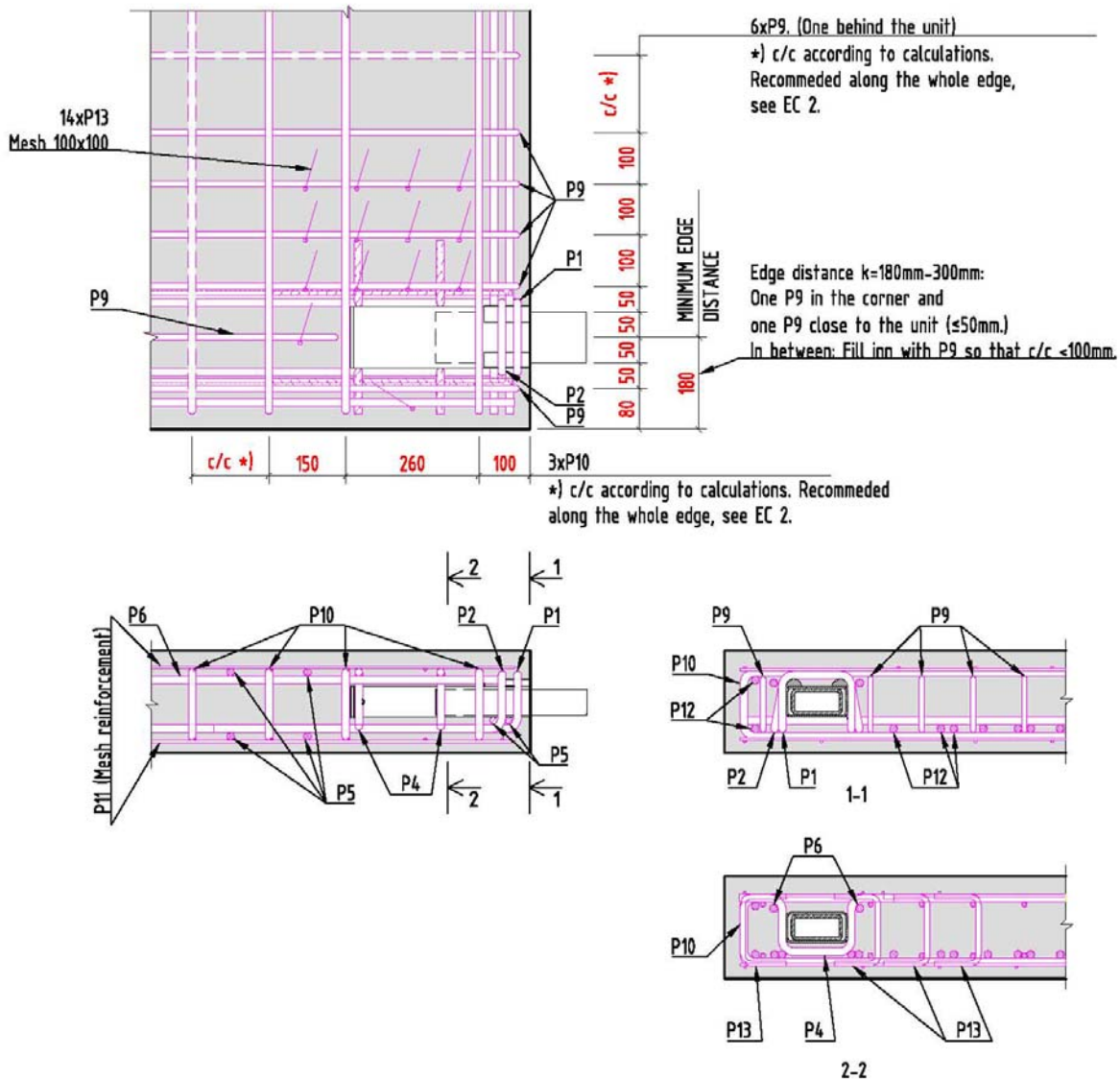

Figure 3: Recommended reinforcement pattern for TSS 101 units. Slab thickness $t < 265\text{mm}$ and edge distance $180\text{mm} \leq k < 300\text{mm}$. Ultimate limit load according to Figure 5.

Date:	26.04.2011	Sign: sss
Last Rev:	04.07.2011	Sign: sss
Doc. No:	K3-10/55dE	Control: ps
Page 3 of 8		

Recommended reinforcement pattern TSS 101

The following comments can be made in connection with the recommended reinforcement pattern shown in Figure 1:

- Reinforcement is illustrated in a slab with thickness 265mm, concrete cover 30mm and large edge distance.
- In the area marked "c/c*", the tested elements (thickness t=265mm) were reinforced with P9 c/c 150mm along the whole edge.
- Two stirrups P9 to be placed closed to the unit. One on each side. Edge reinforcement P9 beyond the prescribed locations should be in accordance with calculations. However, according to EC 2 clauses 6.4.2(5) and 9.3.1.4, stirrups continuously along the edge are always recommended.
- Transverse reinforcement P5 in the bends of P9. When the concrete cover is 25mm, or less, the upper P5 bar can run above the half round steel in front of the unit. With 30mm concrete cover, the upper P5 bar may have to be cut. Then, a straight bar P8 is to be placed transverse of the unit as illustrated, in overlap with P5. If possible, the P5 bar should be made continuously, and to achieve this, it is preferable to lower the unit below the minimum value of 70mm from the top.
- The illustrated reinforcement is the necessary reinforcement required to transfer the forces in the unit to the concrete. It is not to be understood as the complete slab reinforcement. The main reinforcement for the slab/landings, inclusive edge reinforcement must be calculated in each case.

The following comments can be made in connection with the recommended reinforcement pattern shown in Figure 2:

- Reinforcement is illustrated in a slab with thickness 265mm, concrete cover 30mm and edge distance 180mm.
- In the areas marked "c/c*", the tested elements (thickness t=265mm) were reinforced with P10 c/c 150mm and P9 c/c 150mm along the two edges.
- Mesh reinforcement with transverse reinforcement P10 (closed bars) below. P10 runs above the unit, and below P1/P2. The mesh reinforcement may be replaced with straight bars with corresponding cross section area and c/c distance.
- Slab thickness t=200mm: When the unit is located at 400mm, or closer to the corner than 400mm, stirrups **shall always** be used along both edges as prescribed (P9/P10).
Slab thickness t=265mm: When the unit is located at 450mm, or closer to the corner than 450mm, stirrups **shall always** be used along both edges as prescribed (P9/P10).
These stirrups anchor the main reinforcement, and will in addition function as shear reinforcement in the slab. Edge reinforcement P9/P10 beyond the prescribed locations should be in accordance with calculations. However, according to EC 2 clauses 6.4.2(5) and 9.3.1.4, stirrups continuously along the edge are always recommended.
- P10 may be replaced with u-shaped stirrups in overlap with straight bars.
- The illustrated reinforcement is to be understood as a minimum of reinforcement which always should be found when the unit is located close to the corner. It is not to be understood as the complete slab

Date:	26.04.2011	Sign: sss
Last Rev:	04.07.2011	Sign: sss
Doc. No:	K3-10/55dE	Control: ps
Page 4 of 8		

Recommended reinforcement pattern TSS 101

reinforcement. The main reinforcement for the slab/landings, inclusive edge reinforcement must be calculated in each case.

The following comments can be made in connection with the recommended reinforcement pattern shown in Figure 3:

- Reinforcement is illustrated in a slab with thickness 200mm, concrete cover 30mm and edge distance 180mm. Notice the reduction in load in this case, see Figure 5.
- In the areas marked "c/c*", the tested elements (thickness t=200mm) were reinforced with P10 c/c 150mm and P9 c/c 100mm along the two edges.
- Mesh reinforcement with transverse reinforcement P10 (closed bars) below. P10 runs above the unit, and below P1/P2. The mesh reinforcement may be replaced with straight bars with corresponding cross section area and c/c distance.
- Slab thickness t=200mm: When the unit is located at 400mm, or closer to the corner than 400mm, stirrups **shall always** be used along both edges as prescribed (P9/P10).
Slab thickness t=265mm: When the unit is located at 450mm, or closer to the corner than 450mm, stirrups **shall always** be used along both edges as prescribed (P9/P10).
These stirrups anchor the main reinforcement, and will in addition function as shear reinforcement in the slab. Edge reinforcement P9/P10 beyond the prescribed locations should be in accordance with calculations. However, according to EC 2 clauses 6.4.2(5) and 9.3.1.4, stirrups continuously along the edge are always recommended.
- When the slab thickness is less than 265mm, and the unit is located closer to the corner than 300mm, stirrups P13 (shear reinforcement) may be used in the corner area, as illustrated, to increase the concrete capacity, see Figure 5.
- P10 may be replaced with u-shaped stirrups in overlap with straight bars.
- Transverse reinforcement 4Ø12 –P5 behind the unit as illustrated.
- The illustrated reinforcement is to be understood as a minimum of reinforcement which always should be found when the unit is located close to the corner. However, it is not to be understood as the complete slab reinforcement. The main reinforcement for the slab/landings, inclusive edge reinforcement must be calculated in each case.

General comments in connection with both reinforcement patterns:

- Minimum slab thickness: t=200mm. Notice the reduction in load, see Figure 5.
- Minimum concrete cover TSS: 70mm (top flange of the outer tube).
- P1 and P2 to be placed directly onto the unit, with the half round steel positioned in the bend of P1/P2. It is recommended to spot weld P1 and P2 to the unit in order to ensure the correct position.

Recommended reinforcement pattern TSS 101

- Position, shape and anchorage of the stirrups P1 and P2 in the front is the governing factor concerning force transfer from the unit to the slab. Exact and careful detailing is therefore important. Inaccuracy may cause minor concrete cracks to develop before activating the reinforcement as assumed.
- Transverse reinforcement in the bend of P1/P2 (P5). P5 shall have the same diameter as P1/P2 and should run along the whole width of the slab.
- The transverse reinforcement P5 may be a part of the main transverse reinforcement and should have proper anchoring on the outside of the unit on both sides, especially towards the edge. This may require anchoring of P5 with an upward bend, or u-shaped bars. The required anchoring must be evaluated in every case.
- P1 and P2 should be anchored to the maximum depth, depending on the slab thickness.
- The inner width of the stirrups P1 and P2 should correspond to the width of the outer tube. This in order to have the most direct transfer of forces from the outer tube to the vertical legs of the stirrups.
- The main reinforcement of the slab should have sufficient overlap with P1 and P2. This is illustrated with four straight bars P12. The total amount of main reinforcement must be calculated in each case.
- All recommended reinforcement assumed to continue beyond the boundary of the illustrated area shall have a proper anchoring on the outside of the area. Thus, the reinforcement should continue at least one anchoring length outside the illustrated area, or be anchored by hooks.
- Shear reinforcement due to punching shear according to EC 2, clause 6.4.3.

Tolerances on location of anchoring bars:

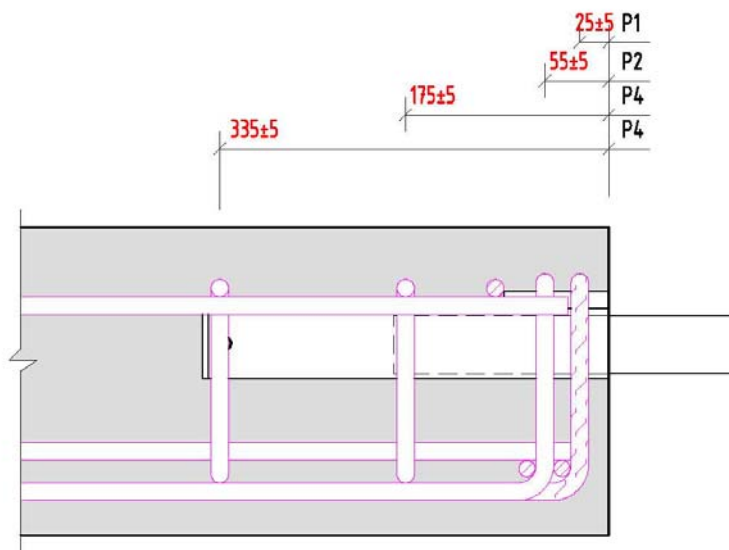

Figure 4: Tolerances P1, P2 and P4.

Recommended reinforcement pattern TSS 101

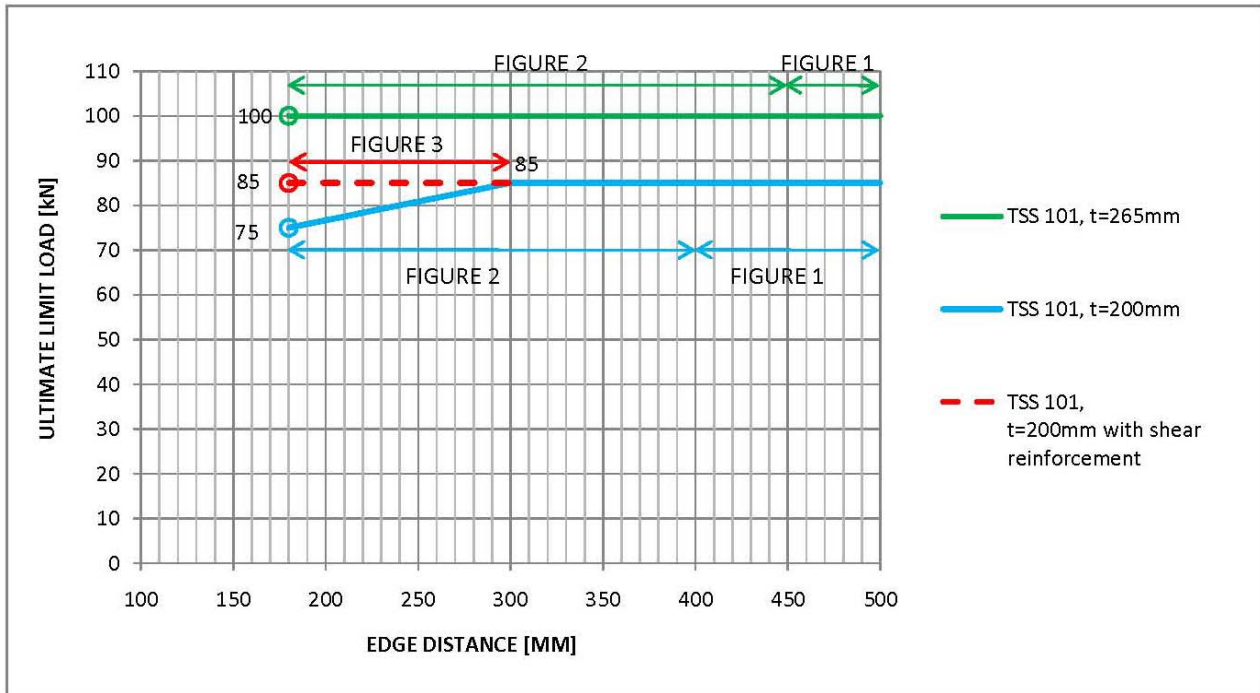
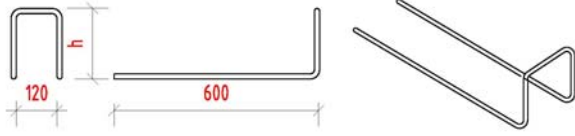
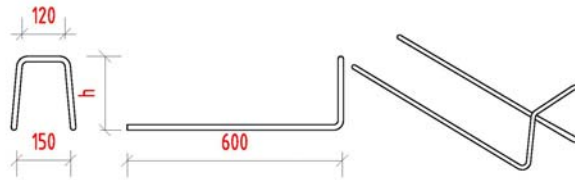
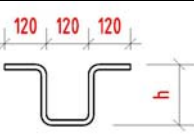





Figure 5: Slab thickness, recommended reinforcement pattern and load limitations. The coloured arrows refer to the recommended reinforcement patterns, as given in above Figures. The colour of the arrow giving the recommended reinforcement pattern corresponds to the colour of the line giving the load limitation. (In Memo 53, Figure 3, the load limitation is illustrated alone, without the arrows and references to reinforcement pattern)

Recommended reinforcement pattern TSS 101

Pos	Diameter	Cutting length	Nr. Pr unit	Bar schedule	Grade
P1	12		1	 <p>Mandrel diameter=32mm (if this is in accordance with national regulations.) h=Decided locally, but as deep as possible. Normally: Slab thickness - 40mm - national rules for concrete cover. If the mandrel diameter is $4x\varnothing$ (in accordance with EC-2) the width should be increased to 130mm to ensure good contact between the stirrups and the round steel.</p>	B500C
P2	12		1	 <p>Mandrel diameter=32mm (if this is in accordance with national regulations.) h=Decided locally, but as deep as possible. Normally: Slab thickness - 40mm - national rules for concrete cover. If the mandrel diameter is $4x\varnothing$ (in accordance with EC-2) the widths should be increased to respectively 130mm and 160 mm to ensure good contact between the stirrups and the round steel.</p>	B500C
P4	12		2	 <p>h= Decided locally. Normally: Slab thickness – 30mm – 2 x national rules for concrete cover.</p>	B500C
P5	12		2 6 ²⁾	 <p>Normally: Width of slab – 2 x national rules for concrete cover.</p>	B500C
P6	12	1000	2		B500C
P7	12	1000	2	 <p>Slab thickness $t=200\text{mm}$: There is not enough space for the bars, and they don't need to be used.</p>	B500C

Recommended reinforcement pattern TSS 101



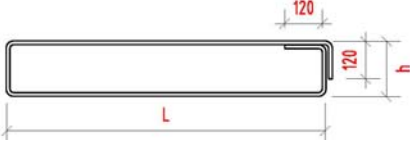

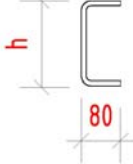
Pos	Diameter	Cutting length	Nr. Pr unit	Bar schedule	Grade
P8	12		1	 <p>Normally: Width of slab – 2 x national rules for concrete cover. Alternatively u-shaped or closed stirrups may be used.</p>	B500C
P9	10		2 + 3 ¹⁾ + 6 ²⁾ +	 <p>h= Decided locally. Normally: Slab thickness – 30mm – 2 x national rules for concrete cover. Recommended along whole edge.</p>	B500C
P10	12		3 ^{1),2)} +	 <p>h= Decided locally. Normally: Slab thickness – 2 x national rules for concrete cover – thickness of mesh reinforcement.</p>	B500C
P11				Minimum mesh reinforcement K131, or main reinforcement in both directions with corresponding cross section area and c/c.	B500C
P12	12		4 + 5 ^{1),2)} +	 <p>The amount of main reinforcement must be according to calculations in each case. Minimum 4xØ12 in overlap with P1/P2 as illustrated. Normally: Length of slab – 2 x national rules for concrete cover</p>	B500C
P13	8		14 ²⁾	 <p>h= Decided locally. Normally: Slab thickness – 2 x national rules for concrete cover – thickness of mesh reinforcement.</p>	B500C
<p>¹⁾ Edge distance ≤ 400mm. Slab thickness, t=200mm. Edge distance ≤ 450mm. Slab thickness, t=265mm. ²⁾ Edge distance < 300mm and slab thickness t < 265mm</p>					

Table 1: List of reinforcement TSS 101.