

Design of Structural Steelwork Elements according to Eurocode 3 EN 1993:2005

Classification of cross-sections, Resistance of cross-sections in single and combined actions, buckling resistance of members. Design of connections. Design of beams, columns, frames, of roof and floor structures. Design of purlins and bracing systems. Design of footings of steel structures. Parameters according to National Annex of Eurocode. Detailed reports with references to Eurocode paragraphs and necessary drawings. Tables with all international steel profiles with dimensions, resistance and buckling resistance values. User defined steel section properties. Welded steel sections formed by the user.

USER's Manual

License and Copyright

If you do not agree with the terms of the following Disclaimer and License Agreement, return the program before you install and activate it, to RUNET Norway as, within 30 days of purchase for a full refund of software cost and sales tax.

Disclaimer

This software should be used only from experienced and licensed professional engineers. The software must be considered as a helping tool for the designer engineer, and can never replace the knowledge, the experience and the judgment of a professional engineer. The user of this software must understand that no matter how advanced and well checked this software is, he should carefully check the results and take responsibility of their use.

Copyright

This software is owned by RUNET Norway as, and it is protected by EC (European Community) Copyright Laws and International Treaty Provisions. This software and the accompanying materials must be treated like any other copyrighted material (e.g. book). It is allowed although to make one copy of the Software for backup or archive purposes. You may not copy and distribute the accompanying materials. It is strictly prohibited by law unauthorized reproduction or resale of this software product and the accompanying materials.

Software License

This is a legal agreement between the legal user of this software and RUNET Norway as. By installing this software you agree to be bound by the terms of this agreement. If you do not agree to the terms of this agreement then do not install this software and return within 30 days after purchase, for a fully refund of your payment.

Scope of License

Each licensed copy of **STEELexpress**, must be used either on a single computer, or installed on a single workstation used non-simultaneously by multiple people, but not both. This is not a concurrent use license.

You may not rent or lease this software. You may not modify, adapt, translate, reverse engineer, decompose, or disassemble the software. Any violation of this agreement terminates your right to use this software.

Liability Limitations

STEELexpress, in no event shall be liable for any damages whatsoever (including without limitations, damages for loss of business profits, business interruption, or any other loss) arising of the use of this software. RUNET makes no warranties, either expressed or implied, as to the quality or performance of this software, that the results and calculations of this software will meet your requirements, or that the operation of this software will be error free.

This software is a helping tool to aid you in the design of timber structures. The results of this software must be reviewed and interpreted from experienced licensed engineers, and by no means constitute an acceptable engineering design.

STEELexpress and related documentation are provided "AS IS" and without warranties as to performance or merchantability or any other warranties whether expressed or implied. Because of the various hardware and software environment into which this software may be put, no warranty of fitness for a particular purpose is offered.

Under no circumstances shall RUNET Norway as and its personal be liable for any direct or indirect, incidental special or consequential damages resulting from the use or inability to use of this software or related documentation, even if RUNET Norway as has been advised of the possibility of such damages.

This agreement shall be governed by EC (European Community) laws. If for any reason a court or competent jurisdiction finds any provision of this agreement, or portion thereof, to be unenforceable, that provision of the agreement shall be enforced to the maximum extend permissible so as to effect the intent of the parties, and the remainder of this agreement shall continue in full force effect.

If this license is too restrictive with the laws of your country, do not use this software and return within 30 days after purchase, for a fully refund of your payment.



Contents

1	General about STEELexpress	5
1.1	Steelwork elements included in the program.....	5
2	After program installation.....	7
3	Basic philosophy in program use	7
3.1	The basic steps in using the program are:	8
4	Design objects	8
5	Calculation Window	9
6	Files	10
7	Step by step, program use	10
8	Parameters.....	12
8.1	National Annex	12
8.2	Materials	12
8.3	Design Parameters	13
8.3.1	NAD parameters	13
8.3.2	Eurocode 3, design parameters.....	13
8.3.3	Critical elastic moment for lateral torsional buckling M_{cr}	13
8.3.4	Parameters for Portal frames	14
8.4	Snow load on the ground	15
8.5	Basic wind velocity	15
8.6	Seismic zone	15
9	General input data for steelwork components	16
9.1.1	Name of design object.....	16
9.1.2	Structural steel grade Eurocode 3 EN1993-1-1:2005 § 3.2.....	16
9.1.3	Partial safety factors for actions Eurocode 0 EN 1990:2002 § 6, Piv. A1.2, A1.3, A1.4	17
9.1.4	Partial factors for materials Eurocode 3 EN1993-1-1:2005 § 6.1	17
9.1.5	Actions Eurocode 0 EN 1990:2002 § 6.3	17
10	Eurocode 3, Tables and charts	19
11	Design tables for Structural Steel Sections,	20
	(Eurocode 3, EN1993-1-1:2005 § 5.5)	20
11.1	Tables with dimensions and properties of standard steel sections	20
11.2	Classification and resistance of standard steel sections.....	21
11.2.1	Symbols	21
11.3	Tables of non-standard steel sections.....	22
11.4	Tables of user defined welded steel sections	22
11.5	Classification and resistance of steel sections (detailed report).....	23
12	Resistance of cross-sections (Eurocode 3, EN1993-1-1:2005 § 6.2)	24
13	Buckling resistance of members (Eurocode 3, EN1993-1-1:2005 § 6.3)	25
13.1	Uniform members in compression EN1993-1-1:2005 § 6.3.1	25
13.1.1	Columns with axial load only	25
13.2	Uniform members in bending EN1993-1-1:2005 § 6.3.2.....	25
13.2.1	Beams with vertical load only	25
13.3	Uniform members in bending and axial compression,	26
	(EN1993-1-1:2005 § 6.3.3)	26
13.3.1	Columns with axial compression and end moments	26
13.3.2	Beams with vertical load and axial compression	27
14	Connections EN1993-1-8:2005	27
14.1	Connection types.....	27
14.1.1	Tension connections (design and capacity)	27
14.1.2	Beam to beam connections (design and capacity)	27
14.1.3	Beam to column connections	28
14.1.4	Connections of portal frames	28
14.1.5	Connections made with pins (design and capacity)	28
14.2	Connection data	29
14.2.1	Connection loading.....	29
14.3	Connection bolts EN1993-1-8 §3.1	29
14.4	Connection plates	29
14.5	Joint geometry	29
15	Design of Steel Beams	30
15.1.1	Beams in Uniform load.....	30
15.2	Design of floor beams	30
15.3	Design of Roof beams	31



15.4	Design of Purlins	31
16	Design of Steel Columns	32
16.1	Column design	32
16.2	Columns in simple constructions.....	32
17	Design of single-bay steel portal frames.....	33
17.1	Basic structure dimensions	33
17.2	Design parameters for buckling control	33
17.3	NAD parameters.....	34
17.4	Cross-sections.....	35
17.5	Estimate of member sizes.....	35
17.6	Portal frame Connections.....	35
17.7	Portal frame loading.....	36
17.7.1	Single Bay portal frame under snow, wind and seismic load	36
17.7.2	Single Bay portal frame under vertical and horizontal load	37
17.7.3	Single Bay portal frame under vertical and horizontal load with concentrated loads on the columns	38
18	Design of Bracing systems	38
18.1.1	Example	39
19	Fundamentals of Steel columns	39
19.1	Loading on the fundament	39
19.2	Dimensions of Fundament	40
19.3	Estimate of fundament dimensions (pre-dimensioning)	40
19.4	Steel Tie and Passive earth pressure	40
19.5	Foundation, Bearing resistance.....	40
20	Base Plate design.....	41
20.1	Loading	42
20.2	Anchor type	42
20.3	Bearing capacity of concrete base.....	42
21	Short theoretical overview.....	43
21.1	Units.....	43
21.2	Coordinate system	43
21.3	Design Loads, EN1991:2005 :	43
21.3.1	Permanent loads, EN1991-1:2005.....	43
21.3.2	Imposed loads EN1991-1:2005.....	43
21.3.3	Snow load EN1991-3:2003.....	43
21.3.4	Wind load of EN1991-4:2005.....	44
21.3.5	Earthquake loading EN1998-1:2004	44
21.4	Design load combinations EN1990:2002	45
21.4.1	Load combination factors (EN1990 Tab.A1.1)	45
21.4.2	Ultimate Limit State (ULS) (EQU)	45
21.4.3	Ultimate Limit State (ULS) (STR)	45
21.4.4	Serviceability Limit State (SLS).....	45
21.4.5	Ultimate Limit State (ULS) Seismic situation.....	45
21.5	Materials EN 1993-1-1:2005 § 3.2.....	45
21.5.1	Steel grades included in the program	45
21.6	Partial factors EN 1993-1-1:2005 § 6.1	46
21.7	Second order effects EN1993-1-1 §5.2.1	46
21.8	Imperfections EN1993-1-1 §5.3.1.....	47
21.9	Steel section types included in the program	48
21.10	Classification of cross sections EN 1993-1-1:2005 § 5.5	49
21.11	Ultimate limit states EN 1993-1-1:2005 § 6.2	51
21.11.1	Tension EN 1993-1-1:2005 § 6.2.3	51
21.11.2	Compression EN 1993-1-1:2005 § 6.2.4	51
21.11.3	Bending moment EN 1993-1-1:2005 § 6.2.5	52
21.11.4	Bi-axial bending EN 1993-1-1:2005 § 6.2.9	53
21.11.5	Shear EN 1993-1-1:2005 § 6.2.6	53
21.11.6	Buckling resistance of uniform members in compression	54
21.11.7	Lateral torsional buckling for uniform members EN 1993-1-1:2005 § 6.3.2 56	
21.11.8	Uniform members in bending and compression EN 1993-1-1:2005 § 6.3.4.....	57
22	Standards and Bibliography	59



1 General about STEELexpress

The software **STEELexpress** covers the design and analysis of structural steelwork elements according to Eurocode 3 EN 1993:2005. In a unified environment you design steelwork elements in a simple way. The design of steel structural components cover many needs of a structural design firm. It simplifies all the repetitive and time-consuming every day calculations for concrete elements. In addition, with the analytical reports and Eurocode references, helps for engineers and engineering students to gain familiarity with design according to Eurocode 3.

In a graphical added environment you specify the necessary dimensions, loads and design code parameters of steel components, and the design is immediately performed. Default values and checks for erroneous input values, facilitate the input data process. The detailed calculations can be viewed immediately.

The report, which is created simultaneously, shows in detail all the calculations and the design steps with references to the corresponding design code paragraphs. In case of inadequate design warnings in red colour appear in the report, and on the calculation window. The report quality is high with sketches, graphs and formulas, and with user specified title block, logos and fonts.

In one project you can create as many structural elements (design objects) as you desire. All the data are stored automatically in one file. A dedicated window helps you working with the design objects in a project. Each structural element is well marked with a name and an icon.

You can edit, copy or delete design objects in a project with a click of the mouse.

You can select the design objects to be included in the final project report.

With double clicking on a design object you enter its calculation window. With right clicking on a design object you can select actions like computations, report previewing and export file, or drawing.

A help system, guides you through the use of the program and the Eurocode provisions. On-line user's manual and frequently asked questions (F.A.Q.) are included in the program.

The design code parameters and the material properties are according to the requirements of the National Annex. The user can select National Annex region. Parameters and materials can also be adjusted by the user.

1.1 Steelwork elements included in the program

- **Basic design charts and graphs of Eurocode 3**
 - Buckling curves
 - Elastic critical moment for lateral buckling M_{cr} ,
 - Effective length of braced and unbraced members
- **Steel sections**
 - dimensions, geometric properties
 - classification
 - resistance values
 - buckling resistance and lateral buckling resistance for various buckling lengths.
- **Resistance of cross-sections for various single or combined actions**
- **Buckling and lateral buckling of members**
- **Connections of steel members**
 - Simple tension connections (single double shear and splice joints)
 - Beam to beam connections (beam continuation, Gerber connection, connection with web cleats)
 - Beam to column connections (with web cleats or end plates)
 - Portal frame connections (Apex connection, eve connections simple or with



- hunch, Base connections simple or fixed).
- Connections with pins. (Pin ended member, Gerber beam)
- **Steel Beam design**
 - Single beams (simply supported, fixed in one end or fixed in both ends). Combination of uniform triangular or concentrated loads. Various lateral length supports.
 - Floor beams of one or two spans or one span and cantilever. Laterally unrestrained, restrained at one or two intermediate points, or totally restrained.
 - Roof beams of one or two spans. Snow, wind pressure and under pressure, imposed load.
 - Purlin design. Simply supported or continuous. Laterally restrained or unrestrained.
- **Steel column design**
 - Single members in compression (various end conditions and buckling lengths)
 - Columns under axial load, or axial load and single or double bending.
 - Columns in simple constructions (simple columns, columns in braced or unbraced frames)
- **Steel frame design**
 - Single bay portal frames under vertical and horizontal loadings
 - Single bay portal frames under vertical and horizontal loadings, with concentrated loads on the columns
 - Single bay portal frames under snow, wind and seismic loading.
- **Design of bracing systems**
 - Vertical bracing system
 - Horizontal bracing systems
- **Design of footings of steel structures**
 - Pinned footing under vertical and horizontal loading
 - Fixed footing under vertical and horizontal loading and moment
 - Footings resisting horizontal forces only with passive earth pressure
 - Footings with horizontal ties in order to resist horizontal forces
 - Design base plate design and base anchoring system. For simple and fixed base connection



2 After program installation

The program is based on the structural Eurocodes. The application as well as the parameters of Eurocodes may differ from country to country.

It is advisable to consult the National Application Documents, which define the parameters, the supporting standards and provide national guidance on the application of Eurocodes.

After the installation of the program, you must select the National Annex of your area. If it is necessary you may also adjust various parameters such as material constants, safety factors Eurocode 3 options, snow and wind regions, and default values.

The user can decide the appearance of the report by adjusting: user defined graphic and logo text, page margins, font selection, size of indentation etc. The Report settings must also be adjusted to meet the requirements of the program user.

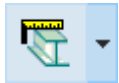

From **Parameters:**

- **NA-National Annex**, Select the National Annex to apply in the design
- **Design Parameters**, Check and select options or modify (if it is necessary) the various design parameters of the Eurocode.
- **Materials**, You can adjust the characteristic material properties. It is advisable to consult the National Application Document of the Eurocodes 0, 1, 2, 6, 7, 8.
- **Snow load on the ground** Default region and snow zone
- **Basic wind velocity** Default region and wind zone
- **Seismic design** Default region and seismic zone



From **Report setup:**

You can adjust the report appearance (margins, font, cover, company logo, page caption, page footnote, indentations, graphic appearance, pagination).

From **[Setup/Decimal point]** you can select type of decimal point symbol.

You can change program language from **[Setup/Language Set-Up]**. By changing the language and confirm it by [apply]. You must recalculate the design objects to take the new language in the report.

From **[Help/Program user's manual]** you can read or print the program user's manual.

3 Basic philosophy in program use

With the program you create and manipulate various design objects or structural steelwork elements. The design objects can be a variety of steelwork parts of a structure such as: beams, columns, connections, simple frame structures, footings, etc. All the program activity takes place within the main window.

Within a project you may create as many design objects as you want. All the data are saved in one project file. A common report is created. You can select the steelwork objects that you want to include in the report. The main window displays and handles all the necessary information and actions for the design objects of the project.

You can create new design objects with the action buttons at the top of the main program window.

Each design object, with a name you specified, and a characteristic icon, is shown in a list in the [Design objects] window. From this window you can regulate their appearance and the order of appearance in the report. The right side window shows the calculations of the selected design object.

By double clicking a design object you enter its calculation window, where you specify the dimensions, the loads and the design code parameters. When the object is created the parameters take the default values. All the required data are well marked with a sketch, and the appropriate dimensions. The program constantly checks for wrong or inappropriately entered values.



With right clicking a design object you can select from the popup menu actions like computation, report previewing, printing, exporting, or CAD drawing. In front of every design object is a check box. Only the objects that are checked will be included in the common report.

3.1 The basic steps in using the program are:

- Open a Project File from menu [File].
- Select a design object, from the [Design objects] window, or create a new one from the action buttons at the top of the main program window.
- Activate the computations of the object, by double clicking the design object or by clicking the computations button. If it is a new object the computations are activated automatically.
- In the object's calculation window enter the necessary data for the particular design object and do the computations.
- In the calculation window you can see the drawing of the object, its reinforcement lay out, and you can preview or print the report of that particular design object.
- Check the objects you would like to appear in the report, and adjust their order of appearance in the [Design objects] window.
- Preview and Print the report and the reinforcing bar schedules, for the marked objects.

Specify the design and code parameters, and the default values from the menu Parameters Adjust the report appearance and the contents. Adjust also the units used in the report. Adjust program appearance and basic parameters.

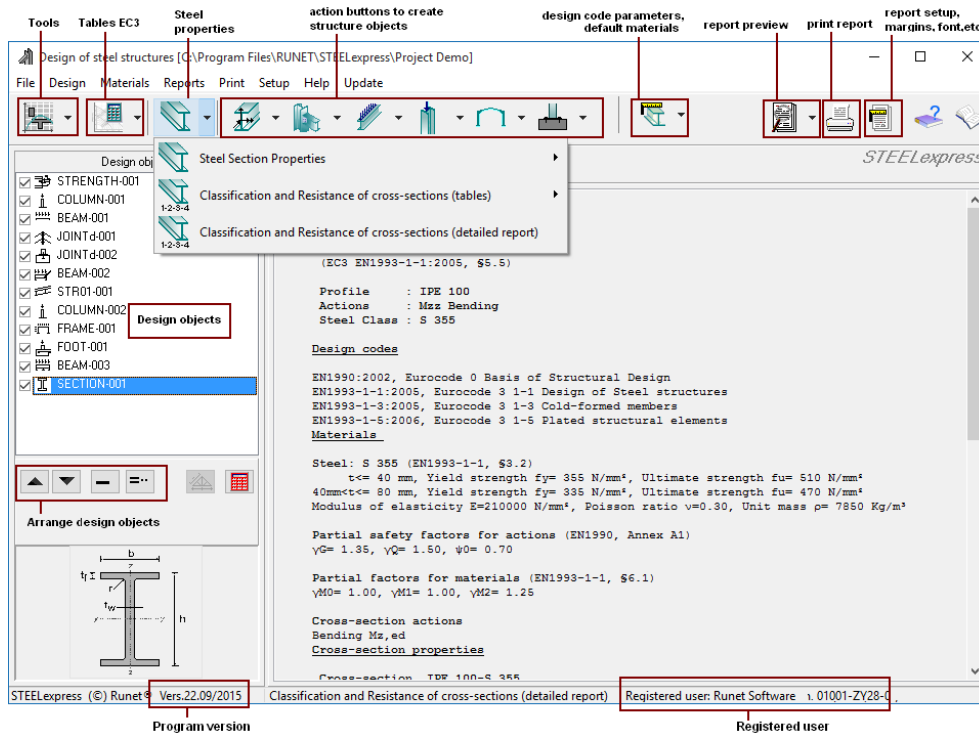

4 Design objects

The design objects can be a variety of steelwork parts of a structure such as: beams, columns, connections, bracing systems, footings etc...





We refer to these calculations as design objects or structural steelwork elements.

You create the design objects with the action buttons on the top. In a project you may create as many design objects, as you want. Automatically the program gives a default name to each object, (which you may change), and assigns a small characteristic icon in front to recognize the type of the design object. You may change the name of the design object. Design objects must have different names.

The design objects are autonomous and each one has its own drawings, material properties and computations. All the design objects of the project are listed in the window at the left, which is the basic window in working with the design objects. By selecting (clicking at) an object, the corresponding computations appear on the right window. If the object appears in red colour, the computations have errors or are not satisfying. A characteristic sketch of the selected design object appears underneath.

With double clicking on a design object you enter its calculation window. With right clicking on a design object you can select actions like computations, report previewing and printing exporting, or drawing.

The objects checked in front, are included in the report. A common report is produced from the selected objects. In the Report Setup you may specify the report of each design object to start in a new page.

The order of the objects, which is also the order of appearance in the report, is regulated with the two buttons  . You can delete one or more selected objects by clicking at Del key or , (multiple selection of design objects with [Shift] and mouse click, or [Ctrl] and mouse click). You can duplicate a selected object by clicking at .

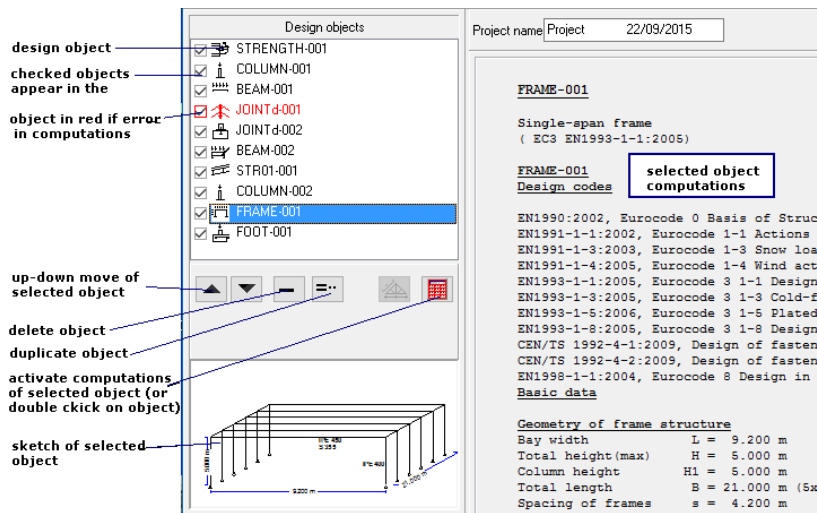

5 Calculation Window

A calculation window has a typical sketch of the steelwork object that is to be designed. All the necessary input data are marked with their dimensions. Depending on the speed of the computer the user can choose to have the computations performed simultaneously with the data input/change or when clicking the button [Computations]

The calculations appear in the window underneath. This window can expand by clicking [Report Up]. Warnings and errors for inadequate design values are shown in red in the calculations.

When the object is created all the parameters take default values. A check is always made for wrong or erroneous input values. After the computations an OK or Error (in red) message is shown on top left. With Preview you can preview the full report of that design object. From the preview window you can print or export the report to PDF or Word file.

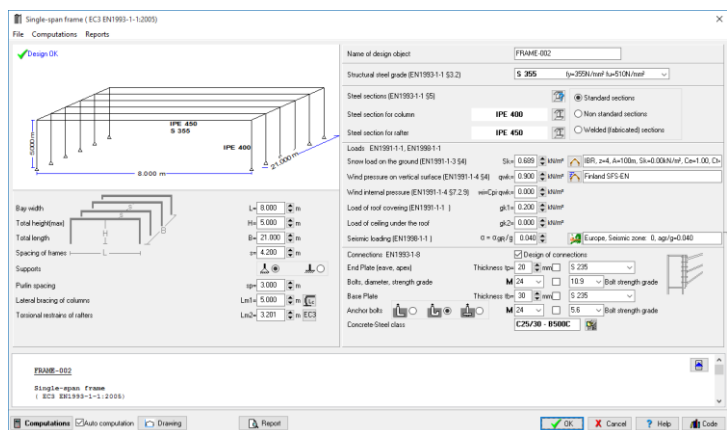

6 Files

You create, open and save files. The data are saved automatically as you change them and you do computations. All the structure objects are saved in the same unique file with an extension [SteelExpressData]. When you specify a new file name you don't have to type in the extension.

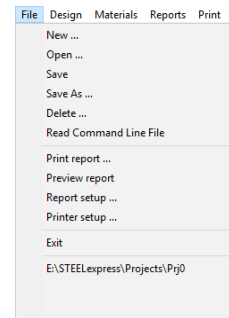

7 Step by step, program use

Open a Project File. Use New for new project and Open for an existing project file. All the data are saved in the same file. The data are saved automatically.

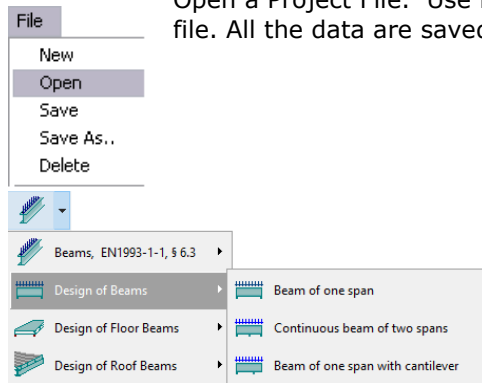

Create a new Design object. From the drop-down buttons on the top, automatically you enter the computation window for this object.

You may select an existing design object, from the [Design objects] window, and activate the computations by double clicking at the object, e.g.

BEAM-001, or by clicking at .

In the window with the computations, enter the necessary data for the particular design object and click on  **Computations** Auto computation. When the Auto-computation is checked, the calculations are performed automatically when you change the data.

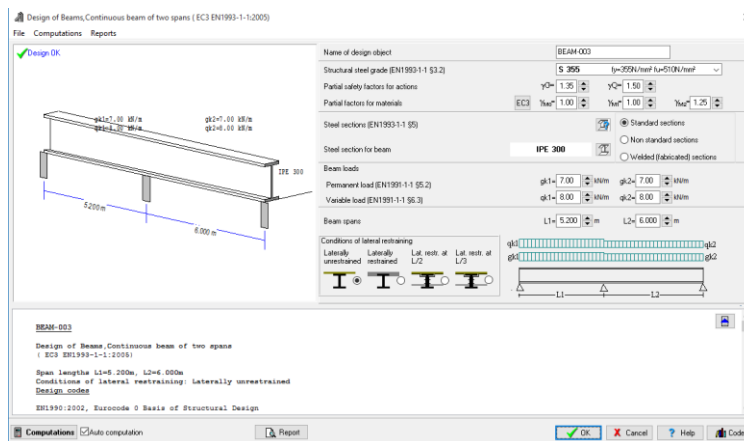

Click to see more of calculations.



✓ Design OK

✗ Error, inadequate design

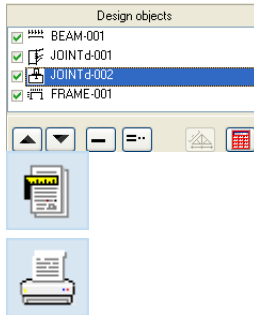
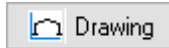

All the computations for the design object are performed.

A message appears if design is OK, the computations and the dimensions are adequate.

If the design has problems due to inadequate dimensions this message will appear.

Automatic generation of CAD drawings.

Preview report. From preview you can export the file to PDF or Word format.

Select (check) the objects you want to include in the report. With the arrows you can adjust their order of appearance in the report. In the report only the objects checked in front will appear.

Report setup. Adjust the appearance of the report. You can adjust: font size, margins, captions and footnotes, line distances, character font, new page after each object printout, line thickness and paragraph indentation
Print the report



8 Parameters

Basic program parameters for materials, design parameters and regions for snow, wind and earthquake loading.

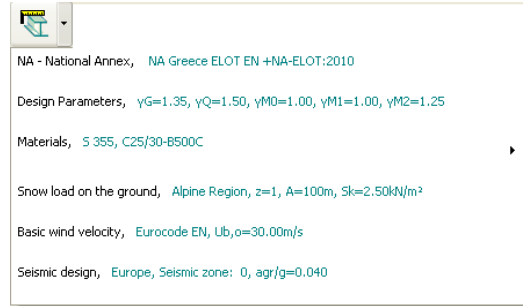

8.1 National Annex

Select the National Annex of the country you want to work. To do this, first click [Locked] to unlock. The various design parameters (load factors, material factors etc.) are set according to the National annex. This does not affect the regions for snow, wind and earthquake, which have to be selected from the next menu lines of the parameter menu.

8.2 Materials

Structural steel, Concrete, Reinforcing steel and Soils for the foundation. You can change (edit) material properties. In order to avoid accidental material changes the edit capabilities are locked. To edit, click first to unlock the edit capabilities. With you add or delete lines from the property tables, with the original program values are loaded.

Reinforcing Steel (EC2 EN1992-1-1:2004, §3.2)

Reinforcing steel Class	f _{yk} [MPa]	f _{tk,c} [MPa]	E _s [GPa]	e _{uk} [%]	L [m]
S220	220.00	220.00	200.00	2.50	14.00
S400	400.00	400.00	200.00	2.50	14.00
S400s	400.00	400.00	200.00	7.50	14.00
S500	500.00	500.00	200.00	2.50	14.00
S500s	500.00	500.00	200.00	7.50	14.00
B500A	500.00	500.00	200.00	2.50	14.00
B500B	500.00	500.00	200.00	5.00	14.00
B500C	500.00	500.00	200.00	7.50	14.00
B450C	450.00	450.00	200.00	7.50	14.00
S670/800	670.00	800.00	200.00	7.50	14.00
B550A	550.00	550.00	200.00	2.50	14.00
B550B	550.00	550.00	200.00	5.00	14.00

f_{yk}: characteristic yield strength, f_{tk,c}: tensile strength, E_s: modulus of elasticity, e_{uk}: maximum strain, L: steel bar length

Concrete properties (EC2 EN1992-1-1:2004, §3.1)

Class	f _{ck} [MPa]	f _{ck,c} [MPa]	f _{ctm} [MPa]	f _{ctk0.05} [MPa]	f _{ctm0.95} [MPa]	f _{ct,fl} [MPa]	f _{vk} [MPa]	E _c [GPa]	G _c [GPa]	w [kg/m ³]
C12/15	12.00	15.00	1.60	1.10	2.00	3.20	0.27	27	11	25
C16/20	16.00	20.00	1.90	1.30	2.50	5.00	0.33	29	12	25
C20/25	20.00	25.00	2.20	1.50	2.90	5.80	0.39	30	13	25
C25/30	25.00	30.00	2.60	1.80	3.30	6.60	0.45	31	13	25
C30/37	30.00	37.00	2.90	2.00	3.80	7.80	0.45	33	14	25
C35/45	35.00	45.00	3.20	2.20	4.20	8.40	0.45	34	15	25
C40/50	40.00	50.00	3.50	2.50	4.60	9.20	0.45	35	15	25
C45/55	45.00	55.00	3.80	2.70	4.90	9.60	0.45	36	16	25
C50/60	50.00	60.00	4.10	2.90	5.30	10.40	0.45	37	16	25
C55/67	55.00	67.00	4.20	3.00	5.50	10.40	0.45	38	16	25
C60/75	60.00	75.00	4.40	3.10	5.70	10.40	0.45	39	16	25
C70/85	70.00	85.00	4.60	3.20	6.00	10.40	0.45	41	16	25
C80/95	80.00	95.00	4.80	3.40	6.30	10.40	0.45	42	16	25
C90/105	90.00	105.00	5.00	3.50	6.60	10.40	0.45	44	16	25

f_{ck}: characteristic cylinder compressive strength at 28 days, f_{ck,c}: characteristic cube compressive strength, f_{ctm}: mean axial tensile strength, f_{ctk0.05}: minimum tensile strength, f_{ctm0.95}: maximum tensile strength, f_{ct,fl}: flexural tensile strength, f_{vk}: shear strength, E_c: modulus of elasticity, G_c: Shear modulus, w: unit weight

Soil properties

Soil type	γ _d [kN/m ³]	γ _s [kN/m ³]	φ°	c [N/mm ²]	q _a [N/mm ²]	q _{uk} [N/mm ²]	E _s [MPa]	μ	K _s [kN/m ³]
Large gravel	16.00	20.00	45.00	0.00	0.30	0.50	80.00	0.15	200000
Mean gravel	16.00	20.00	40.00	0.00	0.30	0.40	70.00	0.15	140000
Thin gravel	16.00	20.00	35.00	0.00	0.30	0.40	60.00	0.15	100000
Dense sand	17.00	20.00	35.00	0.01	0.25	0.30	50.00	0.20	125000
Sand	15.00	19.00	30.00	0.00	0.25	0.30	25.00	0.20	90000
Loose sand	14.00	18.00	25.00	0.00	0.20	0.25	15.00	0.20	30000
Silty sand	21.00	23.00	25.00	0.00	0.15	0.15	10.00	0.25	80000
Clay	20.00	21.00	20.00	0.02	0.15	0.15	5.00	0.30	50000
Clay	20.00	21.00	20.00	0.02	0.15	0.15	5.00	0.30	50000

γ_d: dry unit weight, γ_s: saturated unit weight, φ°: angle of internal friction, c: cohesion, q_a: allowable bearing pressure, q_{uk}: bearing capacity, E_s: modulus of elasticity, μ: Poisson ratio, K_s: modulus of subgrade reaction

8.3 Design Parameters

The National Annex parameters are set according to the National Annex you select. You may although want to change some of them, or specify some design considerations not mentioned in the national Annex.

8.3.1 NAD parameters

- **Action coefficients for Ultimate limit states EQU and STR.** According to Eurocode 0 Table A1.2A and Table A1.2B.

Click Reset to reset to National Annex values.

- **Load Combination coefficients** according to Eurocode 0 Table A1.1.

Click Reset to reset to National Annex values

- **Material factors for Steel** according to Eurocode 3 §6.1

- **Material factors for Reinforced concrete** according to Eurocode 2 §2.4.2.4., used for the reinforced concrete in the foundation.

- **Material factors for Soil** according to Eurocode 7 Annex A. Used for the foundation design.

8.3.2 Eurocode 3, design parameters

Lateral torsional buckling computations base on Eurocode 3 Eq. 6.56, and Tables T 6.3, and T 6.4. (most common)

Lateral torsional buckling computations base on Eurocode 3 Eq. 6.57, and Table T 6.5.

Method for Bending and compression.

Method 1 Annex A or method 2 Annex B (most common)

8.3.3 Critical elastic moment for lateral torsional buckling M_{cr}

The values of coefficients C_1, C_2, C_3 , for the evaluation of elastic critical moment M_{cr} can be found in literature. You may choose the source of definition of these parameters

- **prEN 1993-1-1:2002 Annex C** This is an intermediate publication of Eurocode 3 in 2002. After this the subject has been removed from Eurocode 3.
- **ENV 1993-1-1:1992 Annex F**
- **ECCS 119/Galea SN030a-EN-EU Access Steel 2006**
- **Kolekova Y-Balaz I. Engineering Mechanics 2012**
- **Vagias I., Stahlbau 73(2004), Heft 2**
- **BS5958:1:1990 tables 15 and 16**
- **NSN 6771 Table 9**

Action	ψ_0	ψ_1	ψ_2
Category A (domestic and residential areas)	0.70	0.50	0.30
Category B (office areas)	0.70	0.50	0.30
Category C (common areas)	0.70	0.70	0.60
Category D (shopping areas)	0.70	0.70	0.60
Category E (storage areas)	1.00	0.90	0.80
Category F (parking areas light <=35kN)	0.70	0.70	0.60
Category G (parking areas medium 35kN < ~ <=160kN)	0.70	0.50	0.30
Category H (roofs)	0.00	0.00	0.00
Snow loads on buildings (H<100 m.a.s.l.)	0.70	0.50	0.20
Snow loads on buildings (H<=100 m.a.s.l.)	0.50	0.20	0.00
Wind loads on buildings	0.60	0.20	0.00



8.3.4 Parameters for Portal frames

Specify some parameters that are not covered from national annex. Such as:

1. Deflection limits for Serviceability limit state (SLS)

The limits for these deflections are usually defined in the National Annex. EN1993-1-1 § 7.2 and EN 1990 Annex A1.4 According to EN1993-1-1 these limits may be specified for each project and agree with the client.

Usual values: vertical deflection $L/200$, horizontal deflection $H/150$, vertical deflection due to bending $L/200$.

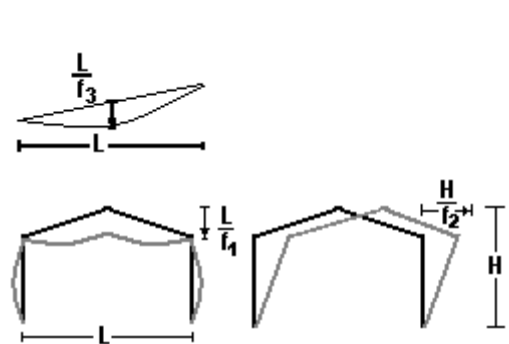
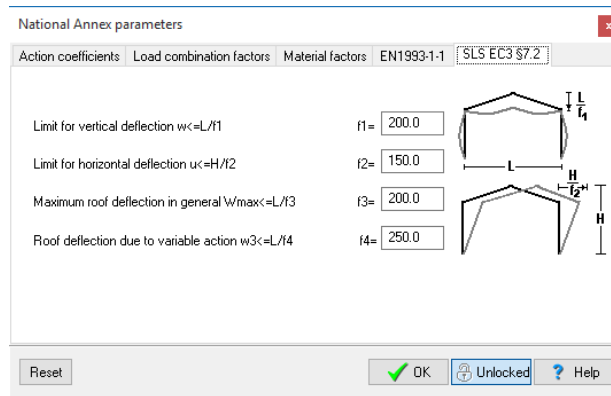

2. Design parameters for buckling control

Columns

(1): (most reasonable default)

- In plane buckling, critical buckling length L_{cr} =system length points of axis.
- Out of plane buckling and torsional buckling and lateral torsional buckling, critical buckling L_{cr} the column height up to the haunch, or the distance of lateral restrains L_{m1} , if is specified smaller than the column length.

(2): (conservatively)

- In plane buckling L_{cr} = system length points of axis.
- Out of plane buckling and torsional buckling and lateral torsional buckling, L_{cr} the system length or the distance of lateral restrains L_{m1} .

Rafters

(1) (most reasonable default)

- In plane buckling L_{cr} = system length. This s computed from the total span L and the first buckling mode.
- Lateral buckling length at span the purlin space, torsional buckling the distance between torsional restraints L_{m2}

(2) (conservatively)

- In plane buckling L_{cr} =system length
- Lateral and torsional buckling length, the distance between torsional restraints L_{m2} .

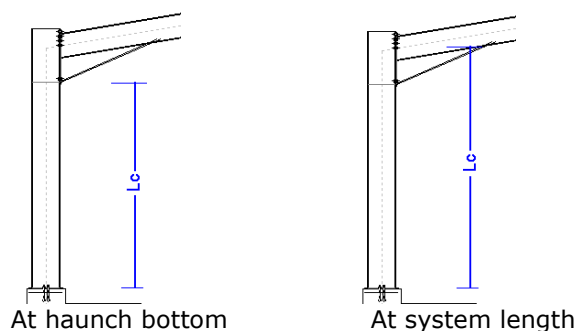

8.4 Snow load on the ground

Default region and snow zone.

Click and select the snow region of your area. The snow zone and the amplitude, and the characteristic snow load value on the ground s_k is set according to Eurocode EN1991-1-3:2003.

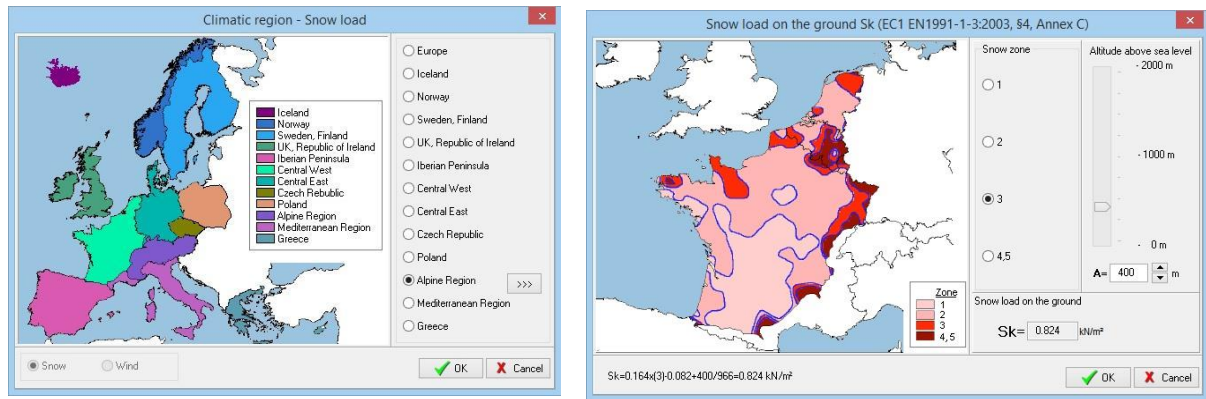

8.5 Basic wind velocity

Select wind region and wind zone. The default basic wind velocity is set.

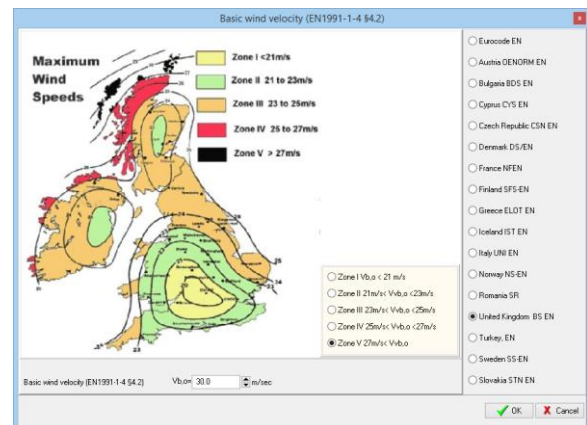

8.6 Seismic zone

Default seismic region and seismic zone. The ground acceleration $a = a_{gr}/g$ is set.

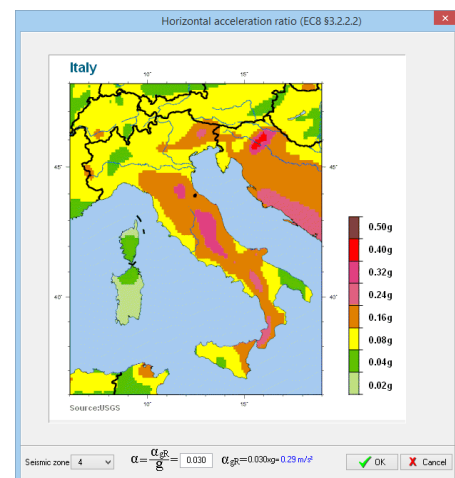

9 General input data for steelwork components

Most of the steelwork design objects have some basic common data as follows:

- Name of design object
- Structural steel grade
- Partial safety factors for actions
- Partial factors for materials
- Actions
- Steel section

Name of design object	STRENGTH-002		
Structural steel grade (EN1993-1-1 §3.2)	S 355 M/ML $f_y=355\text{N/mm}^2$ $f_u=470\text{N/mm}^2$		
Partial safety factors for actions	$\gamma_G=$ 1.35	$\gamma_Q=$ 1.50	
Partial factors for materials	EC3 $\gamma_{M0}=$ 1.00	$\gamma_{M1}=$ 1.00	$\gamma_{M2}=$ 1.25

9.1.1 Name of design object

Every design object has a name, which appears in the report. In the creation of each object the program assigns a default name e.g. Beam-001, Beam-002 etc. which may be changed any time. (names up to 16 characters long). Names of structural design objects must be unique. Two design objects cannot have the same name.

9.1.2 Structural steel grade

Eurocode 3 EN1993-1-1:2005 § 3.2

Select the steel grade from the steel materials available. Most of the used steel grades are included in the program, and are loaded according to the national Annex you select. You can add steel grades, or change properties for steel grades in the menu Parameters/materials/Structural Steel. The program automatically sets the respective steel properties (f_y , f_u , E_s etc.).

S 275	$f_y=275\text{N/mm}^2$ $f_u=430\text{N/mm}^2$
S 235	$f_y=235\text{N/mm}^2$ $f_u=360\text{N/mm}^2$
S 275	$f_y=275\text{N/mm}^2$ $f_u=430\text{N/mm}^2$
S 355	$f_y=355\text{N/mm}^2$ $f_u=510\text{N/mm}^2$
S 450	$f_y=440\text{N/mm}^2$ $f_u=550\text{N/mm}^2$
S 275 N/NL	$f_y=275\text{N/mm}^2$ $f_u=390\text{N/mm}^2$
S 355 N/NL	$f_y=355\text{N/mm}^2$ $f_u=490\text{N/mm}^2$
S 420 N/NL	$f_y=420\text{N/mm}^2$ $f_u=520\text{N/mm}^2$
S 460 N/NL	$f_y=460\text{N/mm}^2$ $f_u=540\text{N/mm}^2$
S 275 M/ML	$f_y=275\text{N/mm}^2$ $f_u=370\text{N/mm}^2$
S 355 M/ML	$f_y=355\text{N/mm}^2$ $f_u=470\text{N/mm}^2$
S 420 M/ML	$f_y=420\text{N/mm}^2$ $f_u=520\text{N/mm}^2$
S 460 M/ML	$f_y=460\text{N/mm}^2$ $f_u=540\text{N/mm}^2$
S 235 W	$f_y=235\text{N/mm}^2$ $f_u=360\text{N/mm}^2$
S 355 W	$f_y=355\text{N/mm}^2$ $f_u=510\text{N/mm}^2$
S 460 Q/QL	$f_y=460\text{N/mm}^2$ $f_u=570\text{N/mm}^2$
S 235 H	$f_y=235\text{N/mm}^2$ $f_u=360\text{N/mm}^2$
S 275 H	$f_y=275\text{N/mm}^2$ $f_u=430\text{N/mm}^2$
S 355 H	$f_y=355\text{N/mm}^2$ $f_u=510\text{N/mm}^2$
S 275 NH/N	$f_y=275\text{N/mm}^2$ $f_u=390\text{N/mm}^2$
S 355 NH/N	$f_y=355\text{N/mm}^2$ $f_u=490\text{N/mm}^2$
S 420 NH/N	$f_y=420\text{N/mm}^2$ $f_u=540\text{N/mm}^2$
S 460 NH/N	$f_y=460\text{N/mm}^2$ $f_u=560\text{N/mm}^2$

9.1.2.1 Steel grades included in the program

S 235	EN 10025-2	$f_y40:235;f_u40:360$
S 275	EN 10025-2	$f_y40:275;f_u40:430$
S 355	EN 10025-2	$f_y40:355;f_u40:510$
S 450	EN 10025-2	$f_y40:440;f_u40:550$
S 275 N/NL	EN 10025-3	$f_y400:275;f_u4:390$
S 355 N/NL	EN 10025-3	$f_y40:355;f_u40:490$
S 420 N/NL	EN 10025-3	$f_y40:420;f_u40:520$
S 460 N/NL	EN 10025-3	$f_y40:460;f_u40:540$
S 275 M/ML	EN 10025-4	$f_y40:275;f_u40:370$
S 355 M/ML	EN 10025-4	$f_y40:355;f_u40:470$
S 420 M/ML	EN 10025-4	$f_y40:420;f_u40:520$
S 460 M/ML'	EN 10025-4	$f_y40:460;f_u40:540$
S 235 W	EN 10025-5	$f_y40:235;f_u40:360$
S 355 W	EN 10025-5	$f_y40:355;f_u40:510$
S 460 Q/QL	EN 10025-6	$f_y40:460;f_u40:570$
S 235 H	EN 10210-1	$f_y40:235;f_u40:360$



S 275 H	EN 10210-1	fy40:275;fu40:430
S 355 H	EN 10210-1	fy40:355;fu40:510
S 275 NH/NLH	EN 10210-1	fy40:275;fu40:390
S 355 NH/NLH	EN 10210-1	fy40:355;fu40:490
S 420 NH/NLH	EN 10210-1	fy40:420;fu40:540
S 460 NH/NLH	EN 10210-1	fy40:460;fu40:560
S 220GD+Z	EN 10147	fy40:220;fu40:300
S 250GD+Z	EN 10147	fy40:250;fu40:330
S 280GD+Z	EN 10147	fy40:280;fu40:360
S 320GD+Z	EN 10147	fy40:320;fu40:390
S 350GD+Z	EN 10147	fy40:350;fu40:420
H240LA	EN 10268	fy40:240;fu40:340
H280LA	EN 10268	fy40:280;fu40:370
H320LA	EN 10268	fy40:320;fu40:400
H360LA	EN 10268	fy40:360;fu40:430
H400LA	EN 10268	fy40:400;fu40:460
H260LAD	EN 10292	fy40:240;fu40:340
H300LAD	EN 10292	fy40:280;fu40:370
H340LAD	EN 10292	fy40:320;fu40:400
H380LAD	EN 10292	fy40:360;fu40:430
H420LAD	EN 10292	fy40:400;fu40:460
220GD+ZA	EN 10214	fy40:220;fu40:300
250GD+ZA	EN 10214	fy40:250;fu40:330
280GD+ZA	EN 10214	fy40:280;fu40:360
320GD+ZA	EN 10214	fy40:320;fu40:390
350GD+ZA	EN 10214	fy40:350;fu40:420

The steel grades for cold formed steel C, Z and U sections are included.

9.1.3 Partial safety factors for actions

Eurocode 0 EN 1990:2002 § 6, Piv. A1.2, A1.3, A1.4

The partial safety γ_G , $\gamma_{G.sup}$ (permanent loads unfavourable), $\gamma_{G.inf}$ (permanent loads unfavourable), γ_Q (variable loads), and coefficients ψ_0 , ψ_1 , ψ_2 for combining actions, are set according to the national Annex selected. They can be changed from the menu Parameters/Design parameters/Action coefficients. And Parameters/Design parameters/Load combination factors.

Common values $\gamma_G=1.35$, $\gamma_{G.inf}=1.00$, $\gamma_Q=1.50$, $\psi_0=0.70$.

9.1.4 Partial factors for materials

Eurocode 3 EN1993-1-1:2005 § 6.1

The material partial factors γ_{M0} , γ_{M1} , γ_{M2} , are set according to the national Annex selected. They can be changed from the menu Parameters/Design parameters/Material factors.

Usual values:

$$\gamma_{M0} = 1.00$$

$$\gamma_{M1} = 1.00$$

$$\gamma_{M2} = 1.25$$

9.1.5 Actions

Eurocode 0 EN 1990:2002 § 6.3

In some cases (as the cases of evaluating the resistance of cross-section) you specify the design value for actions N_{ed} (axial force), M_{ed} (bending moments), etc. which is the result of combining permanent and variable actions.

$$N_{ed} = \gamma_G \cdot N_g + \gamma_Q \cdot N_{q1} + \gamma_Q \cdot \psi_0 \cdot N_{q2} \quad (\text{Eq.6.10})$$

$$M_{ed} = \gamma_G \cdot M_g + \gamma_Q \cdot M_{q1} + \gamma_Q \cdot \psi_0 \cdot M_{q2}$$



In most cases you specify the permanent and variable actions and the program evaluates the design actions.

In cases of designing structural parts as floors, or roofs you specify the environmental loads permanent and variable on the structure.

9.1.5.1 Permanent loads on floors

Weight of floor finishing, the weight of the floor finishing (tiles etc.)

Weight of floor structure then weight of the floor structure If you select thin concrete slab (70mm) or timber floor. The floor beams are checked as unrestrained. For thicker concrete slab are checked restrained, and for steel floor (steel plates etc.) are checked later restrained at one middle point. The lateral restraining selection can be altered afterwards

9.1.5.2 Variable loads on floors

Variable load You can select from the table of EN1991-1-1 6.3).

Floors	2.00 kN/m ²
Floors	2.00 kN/m ²
Stairs	3.50 kN/m ²
Balconies	5.00 kN/m ²
Category B (office areas)	2.00 kN/m ²
C1 -Areas with Tables	3.00 kN/m ²
C2 -Areas with Fixed seats	5.00 kN/m ²
C3 -Areas without obstacles for	5.00 kN/m ²
C4 -Areas with possible physical	5.00 kN/m ²
C5 -Areas susceptible to large c	7.50 kN/m ²
D1 -Areas in general retail shop	5.00 kN/m ²
D2 -Areas in department stores	5.00 kN/m ²
E1 -Storage areas	7.50 kN/m ²
F -Traffic and parking areas<=35	2.50 kN/m ²
G -Traffic and parking areas>35k	5.00 kN/m ²

9.1.5.3 Permanent loads on roofs

- Load of roof covering [kN/m²] It includes the weight of the sheeting, purlins and insulation materials.
- Load of ceiling under the roof [kN/m²]
- self weight of frame elements, calculated by the program from the element cross sections with Unit mass $\rho = 7850 \text{ Kg/m}^3$

Concrete floor 100mm	2.50 kN/m ²
Concrete floor 70mm	1.75 kN/m ²
Concrete floor 100mm	2.50 kN/m ²
Concrete floor 150mm	3.75 kN/m ²
Concrete floor 200mm	5.00 kN/m ²
Concrete floor 250mm	6.25 kN/m ²
Concrete floor 300mm	7.50 kN/m ²
Timber floor	0.30 kN/m ²
Steel floor	0.70 kN/m ²

9.1.5.4 Variable loads on roofs

- Imposed load according to EN1990-1-1 Tab 6.1, calculated by the program according to the selected National Annex
- Snow load according to Eurocode 1-3:2004

The characteristic snow load on the ground s_k is specified in kN/m².

Click , and a special dialog window appear. In this window you set the snow zone and the height above the sea level. The characteristic snow load on the ground is computed according to Eurocode 1-3:2004, and the National Annex. The snow region can be selected from Parameters/snow load on the ground. The snow load on the roof is computed according to Eurocode 1-3:2003.

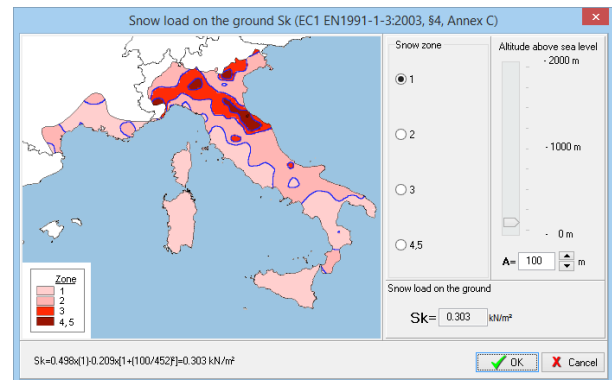

- Wind load, according to Eurocode 1-4:2005

The wind pressure on vertical surface is specified in kN/m². Click  and in this window you compute the wind pressure from the wind velocity and the topography of the region according to Eurocode 1-4:2005. The wind load is computed for various places at the roof and the vertical walls according to Eurocode 1-4:2005 §7.2.5 and Tab 7.4a and Tab. 7.1. The wind region, which specifies the wind

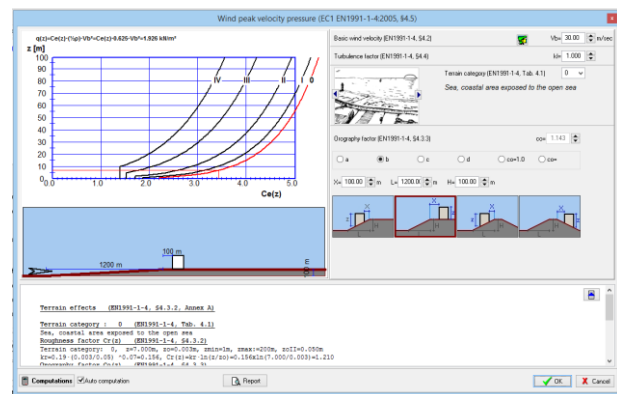

velocity, is selected from Parameters/Basic wind velocity.
 Wind internal pressure w_i in kN/m². This is internal pressure and it acts from inside outwards on the walls and roof. It is subtracted directly (without further multiplication by pressure coefficients) from any uplift wind pressure on the outside surfaces.

9.1.5.5 Seismic load Eurocode 8-1:2004

The program performs a verification of the structure under seismic loading, using both Lateral force method, and Modal superposition spectrum analysis. $\alpha = \alpha_{gR}/g$ 0.160

Basic value used in the seismic design is the ratio of horizontal seismic acceleration. Click  and a special dialog window appears where you may in detail specify all the necessary seismic parameters (soil factors, spectra periods, behaviour factors, etc.) for the design spectrum, according to Eurocode 8-1:2004.

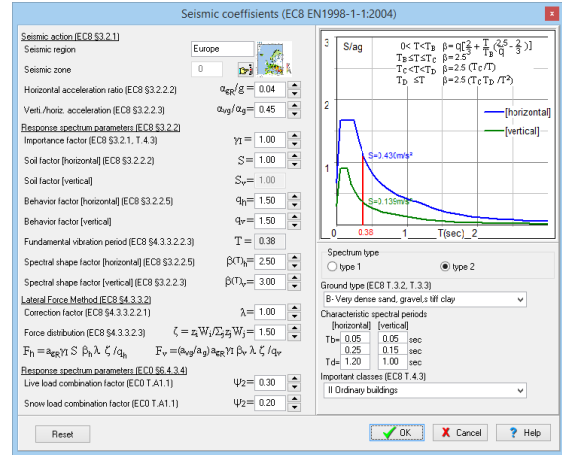

10 Eurocode 3, Tables and charts

From the menu you can see various helpful charts and tables of Eurocode 3.

- Flexural buckling, EN1993-1-1, § 6.3.1
- Lateral torsional buckling, EN1993-1-1, § 6.3.2
- Effective length of columns in braced and unbraced frames.

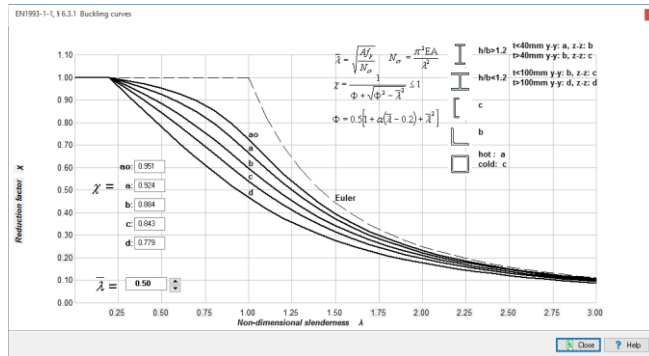
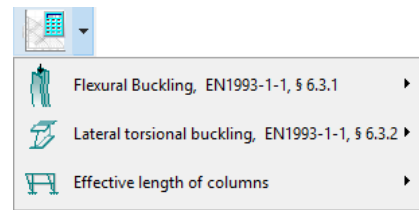

Elastic critical moment for lateral-torsional buckling EN 1993-1-1:2002 Annex C

$$M_{cr} = C_1 \frac{\pi^2 EI_x}{(kl)^2} \left[\left(\frac{k}{k_v} \right)^2 I_x + \frac{(kl)^2 GI_t}{\pi^2 EI_x} + (C_2 Z_x - C_3 Z_y)^2 - (C_2 Z_x - C_3 Z_y) \right]$$

Bending moment diagram	k	C1	C2	C3
	1.00	1.000	1.000	1.000
	0.50	1.127	1.000	1.019
	1.00	1.141	1.000	1.000
	0.50	1.285	1.000	1.017
	1.00	1.320	1.000	1.000
	0.50	1.482	1.000	1.000
	1.00	1.551	1.000	1.000
	0.50	1.730	1.000	1.000
	1.00	1.847	1.000	1.000
	0.50	2.027	1.000	0.950
	1.00	2.207	1.000	1.000
	0.50	2.341	1.000	1.000
	1.00	2.591	1.000	1.000
	0.50	2.979	1.000	0.950
	1.00	2.952	1.000	1.000
	0.50	2.608	1.000	0.850
	1.00	2.733	1.000	0.825
	0.50	2.390	1.000	0.825
	1.00	1.132	0.459	0.525
	0.50	0.967	0.427	0.478
	1.00	1.363	0.553	0.411
	0.50	1.087	0.449	0.338
	1.00	1.040	0.431	0.562
	0.50	0.960	0.404	0.539
	1.00	2.608	1.562	-0.859
	0.50	1.515	0.900	-0.515
	1.00	1.728	1.388	-0.716
	0.50	0.955	0.793	-0.408

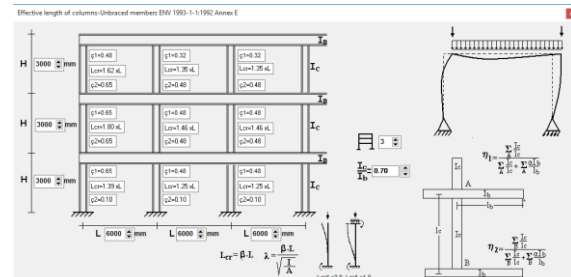
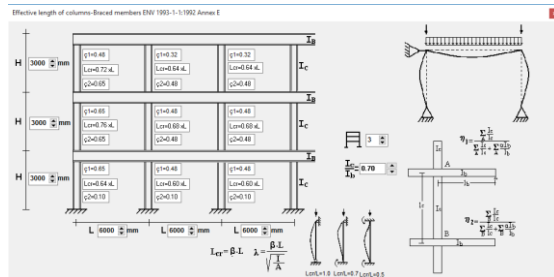

11 Design tables for Structural Steel Sections, (Eurocode 3, EN1993-1-1:2005 § 5.5)

Tables with steel sections, with their **dimensions, properties, classification, resistance and buckling resistance values** according to Eurocode 3

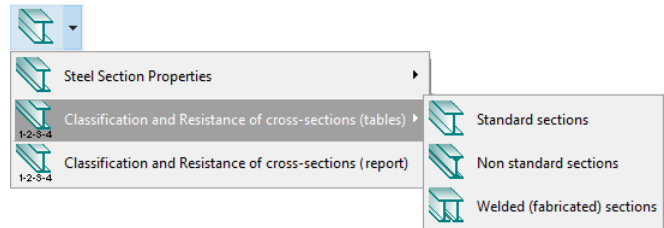

Three (3) groups of sections are included in the program.

- **Standard sections.** All international section profiles.
- **Non-standard sections.** Sections with dimensions given by the user.
- **Welded sections.** Welded sections made from rectangular steel plates, with dimensions given by the user.

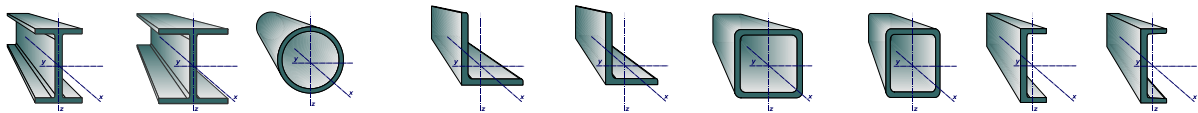

11.1 Tables with dimensions and properties of standard steel sections

From the left tree you select the section type e.g. IPE, HE etc. On the right the table shows all the standard sections for this group and their dimensions and properties. Moving up and down the table on the right the section drawing is shown in scale (you can grab and move the section drawing around the window and you can make it small or bigger with the arrows).

Click or double click on a section and you obtain analytical report for the classification, resistance values and buckling resistance of the selected section.

I	h	b	t _w	t _f	r	A	G	I _y	W _y	W _{pl,y}	I _y	A _{v,z}	I _z	W _z	W _{pl,z}	i _z	A _{v,y}	I _t	I _w
mm	mm	mm	mm	mm	mm	cm ²	Kg/m	cm ⁴	cm ³	cm ³	cm	cm ²	cm ⁴	cm ³	cm ³	cm	cm ²	cm ⁴	cm ⁶
I 80	80	42	3.9	5.9	3.9	7.57	5.94	77.80	19.50	22.70	3.21	3.30	6.29	3.00	5.46	0.912	4.96	0.798	100.0
I 100	100	50	4.5	6.8	4.5	10.60	8.34	171.0	34.20	39.70	4.02	4.72	12.20	4.68	8.94	1.07	6.80	1.47	307.6
I 120	120	58	5.1	7.7	5.1	14.20	11.1	328.0	54.70	63.50	4.81	6.45	21.50	7.41	13.63	1.23	8.93	2.49	789.4
I 140	140	66	5.7	8.6	5.7	18.20	14.3	573.0	81.90	95.20	5.61	8.32	35.20	10.70	19.73	1.39	11.35	3.96	1 779
I 160	160	74	6.3	9.5	6.3	22.80	17.9	935.0	117.0	136.0	6.40	10.54	54.70	14.80	27.41	1.55	14.06	6.01	3 633
I 180	180	82	6.9	10.4	6.9	27.90	21.9	1 450	161.0	187.0	7.21	13.00	81.30	19.80	36.86	1.71	17.06	8.76	6 873
I 200	200	90	7.5	11.3	7.5	33.40	26.2	2 140	214.0	249.0	8.00	15.60	117.0	26.00	48.26	1.87	20.34	12.36	12 222
I 220	220	98	8.1	12.2	8.1	39.50	31.1	3 060	278.0	323.0	8.80	18.55	162.0	33.10	61.79	2.03	23.91	16.97	20 659
I 240	240	106	8.7	13.1	8.7	46.10	36.2	4 250	354.0	411.0	9.60	21.75	221.0	41.70	77.64	2.19	27.77	22.76	33 469
I 260	260	113	9.4	14.1	9.4	53.30	41.9	5 740	442.0	513.0	10.38	25.41	288.0	51.00	95.14	2.32	31.87	30.52	51 258
I 280	280	119	10.1	15.2	10.1	61.00	47.9	7 590	542.0	631.0	11.15	29.43							
I 300	300	125	10.8	16.2	10.8	69.00	54.2	9 800	653.0	761.0	11.92	33.75							
I 320	320	131	11.5	17.3	11.5	77.70	61.0	12 510	782.0	913.0	12.69	38.34							
I 340	340	137	12.2	18.3	12.2	86.70	68.0	15 700	923.0	1 078	13.46	43.26							
I 360	360	143	13.0	19.5	13.0	97.00	76.1	19 610	1 090	1 274	14.22	48.83							
I 380	380	149	13.7	20.5	13.7	107.0	84.0	24 010	1 260	1 480	14.98	54.34							
I 400	400	155	14.4	21.6	14.4	118.0	92.4	29 210	1 460	1 712	15.73	60.37							
I 425	425	163	15.3	23.0	15.3	132.0	104.0	36 970	1 740	2 041	16.74	67.58							
I 450	450	170	16.2	24.3	16.2	147.0	115.0	45 850	2 040	2 394	17.66	76.19							
I 475	475	178	17.1	25.6	17.1	163.0	128.0	56 480	2 380	2 795	18.61	85.00							
I 500	500	185	18.0	27.0	18.0	179.0	141.0	68 740	2 750	3 235	19.60	93.68							
I 550	550	200	19.0	30.0	19.0	212.0	166.0	99 180	3 610	4 229	21.63	109.1							
I 600	600	215	21.6	32.4	21.6	254.0	199.0	139 000	4 630	5 465	23.39	135.7							

11.2 Classification and resistance of standard steel sections

Classification of cross section according to EN1993-1-1:2005 §5.5.
 Resistance values of cross section according to EN1993-1-1:2005 §6.2.
 Buckling resistance and lateral buckling resistance according to EN1993-1-1:2005 §6.3

From the tree on the left you select the section with its designation. On the right, a drawing of the section profile is displayed together with the section dimensions and properties.

On the right window are also displayed:

- **Classification** (1,2,3,4) according to EN1993-1-1:2005 §5.5 for axial loading and loading with bending moments.
- **Resistances** of the section in compression, bending in y-y and z-z axis, and shear according to EN1993-1-1:2005 §6.2
- **Buckling resistance** for various buckling lengths (L_c) according to EN1993-1-1:2005 §6.3.1
- **Lateral torsional buckling resistance** for various lateral buckling lengths (L_{lt}) according to EN1993-1-1:2005 §6.3.2

The screenshot shows the 'Steel section with properties defined by the user, Classification and Resistance, (EN1993-1-1:2005 §5.6, §6.2)' window. On the left is a tree view of steel sections, with 'HP 320x103' selected. The main area displays a technical drawing of the HP 320x103 section with dimensions: depth h=307 mm, width b=306 mm, web thickness tw=14 mm, and flange thickness tf=27 mm. To the right, a table lists the 'Properties of cross section': Area A=13100 mm², Second moment of area Iy=2.205E008 mm⁴, Iz=6.704E007 mm⁴, Section modulus Wy=1.437E006 mm³, and Wz=438200 mm³. Below this, a table provides 'Classification and Resistance of cross section (EN1993-1-1:2005 §5.6, §6.2)' for various steel grades (S 235, S 275, S 355, S 450) and classes (1, 2, 3). It includes columns for Tension (NtRd), Compression (NcRd), Moment resistance (McRdy, McRdz), and Shear resistance (VcRdy, VcRdz). A third table shows 'Buckling resistance, Buckling length Lc[m]' for different Lc values (1.0 to 12.0) and grades. A final table shows 'Lateral torsional buckling resistance, Buckling length Llt[m]' for different Llt values and grades. The bottom of the window has 'Preview', 'Print', 'Close', and 'Help' buttons.

11.2.1 Symbols

- NtRd [kN]:** Tension resistance EN1993-1-1:2005 §6.2.3
- NcRd [kN]:** Compression resistance EN1993-1-1:2005 §6.2.4
- McRdy [kNm]:** Bending resistance about the strong y-y axis EN1993-1-1:2005 §6.2.5
- McRdz [kNm]:** Bending resistance about the weak z-z axis EN1993-1-1:2005 §6.2.5
- VcRdz [kN]:** Shear resistance in the axis z-z parallel to web EN1993-1-1 §6.2.6
- VcRdy [kN]:** Shear resistance in the axis y-y axis parallel to flanges EN1993-1-1:2005 §6.2.6

- Nbrdy [kN]:** Buckling resistance in compression about the strong y-y or weak z-z
- Nbrdz [kN]:** axis, for various buckling lengths L_c (1.00,1.50...15 m) EN1993-1-1:2005 §6.3.1
- Mbrd1 [kNm]:** Lateral torsional buckling resistance for various lengths between
- Mbrd2 [kNm]:** constrains L_{lt} (1.00,1.5015 m) EN1993-1-1:2005 §6.3.2
- Mbrd1:** Lateral torsional buckling resistance for constant (uniform) bending
- Mbrd1:** moment diagram along the beam
- Mbrd2:** Lateral torsional buckling resistance for parabolic bending moment
- Mbrd2:** diagram along the beam

- h [mm]:** Depth of cross section
- b [mm]:** Width of cross section
- hw [mm]:** Web depth
- dw [mm]:** Depth of straight portion of web
- tw [mm]:** Web thickness
- tf [mm]:** Flange thickness
- r [mm]:** Radius of root fillet
- G [Kg/m]:** Mass
- A [cm²]:** Area
- Iy [cm⁴]:** Moment of area about axis y-y
- Iz [cm⁴]:** Second moment of area about axis z-z
- Wy [cm³]:** Section modulus about axis y-y
- Wz [cm³]:** Section modulus about axis z-z
- Wpy [cm]:** Plastic section modulus about axis y-y
- Wpz [cm³]:** Plastic section modulus about axis z-z
- iy [cm]:** Radius of gyration about y-y axis
- iz [cm]:** Radius of gyration about z-z axis
- Avz [cm²]:** Shear area parallel to web
- Avy [cm²]:** Shear area parallel to flanges
- It [cm⁴]:** Torsional constant
- Iw [cm⁶]:** Warping constant

11.3 Tables of non-standard steel sections

Tables with steel sections organized as the standard sections, but the user can change the basic dimensions. Changes are activated with the [Edit]. As you change the dimensions the new geometric and strength properties are evaluated. These sections can be used as standard sections.

11.4 Tables of user defined welded steel sections

Click [Edit] and you enter the window where you can enter the basic dimensions of a welded steel section. The strength properties of the section are listed at the same time.

For adding new section or deleting existing click  . Click [Stop edit] to stop editing.

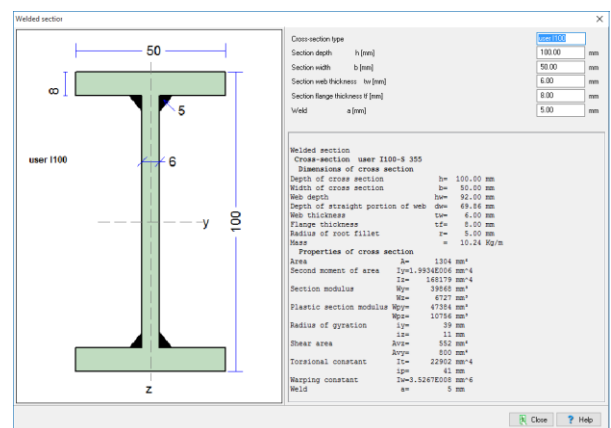
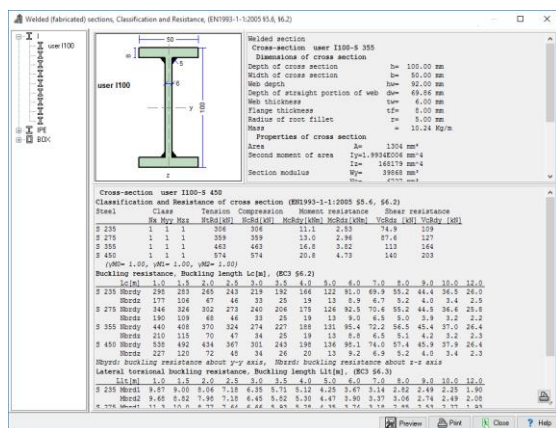

11.5 Classification and resistance of steel sections (detailed report)

1. Select section group (standard, non- standard, welded)
2. From the tree on the left select the section.
3. Select the combination of actions on the cross-section. If it is combination with axial force and bending moments specify the actions.

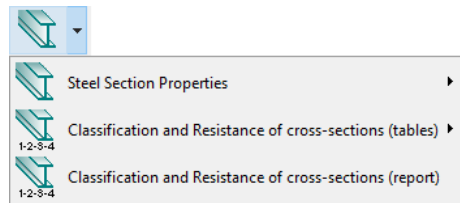

You obtain a detailed report of the section classification according to EN1993-1-1:2005 §5.5. You can adjust also the steel grade and the partial safety factors.

The screenshot displays the software interface for selecting and defining a steel section. On the left, a tree view shows the hierarchy: IPE > HE > HE A (IPB1) Euronorm 53-62 > HE 260 A. A diagram of a standard I-section is shown with dimensions: flange width b , flange thickness t_f , web thickness t_w , height h , and radius r . Below it, a detailed diagram of the HE 260 A section shows a flange width of 260 mm, a web thickness of 7.5 mm, and a height of 260 mm. The main panel shows the design object 'SECTION-001' with a structural steel grade of 'S 275' and various partial safety factors for actions ($\gamma_G=1.35, \gamma_Q=1.50, \psi=0.90$) and materials ($\gamma_{M0}=1.00, \gamma_{M1}=1.00, \gamma_{M2}=1.25$). A dropdown menu for 'Section actions' is open, showing options like 'Nc-ed', 'Mz-ed', and 'Nc-Mz Compression-Bending'. The 'Selected section' is 'HE 260 A' under 'Standard sections'. A table of properties for the HE 260 A section is provided:

Dimensions of cross section	
Depth of cross section	
Width of cross section	
Web depth	
Depth of straight portion	
Web thickness	$t_w = 7.50 \text{ mm}$
Flange thickness	$t_f = 12.50 \text{ mm}$
Radius of root fillet	$r = 24.00 \text{ mm}$
Mass	$= 68.20 \text{ Kg/m}$

Properties of cross section	
Area	$A = 8682 \text{ mm}^2$
Second moment of area	$I_y = 1.045E008 \text{ mm}^4$
	$I_z = 3.668E007 \text{ mm}^4$

12 Resistance of cross-sections (Eurocode 3, EN1993-1-1:2005 § 6.2)

Design of cross-section in Ultimate limit state, for various combinations of actions

Design load combinations

- **Single actions**

- Tension N_t
- Compression N_c
- Bending M_{yy}
- Bending M_{zz}
- Shear V_z
- Shear V_y

- **Double actions**

- Bending and compression N_c-M_{yy}
- Bending and compression N_c-M_{zz}
- Biaxial bending $M_{yy}-M_{zz}$
- Compression and shear N_c-V_z
- Compression and shear N_c-V_y

- **Combined actions**

- Compression, bending and shear $N_c-V_z-M_{yy}$
- Tension, bending and shear $N_t-V_z-M_{yy}$
- Bending and compression $N_c-M_{yy}-M_{zz}$
- Bending and tension $N_t-M_{yy}-M_{zz}$
- Axial force shear and bending $N-V-M$

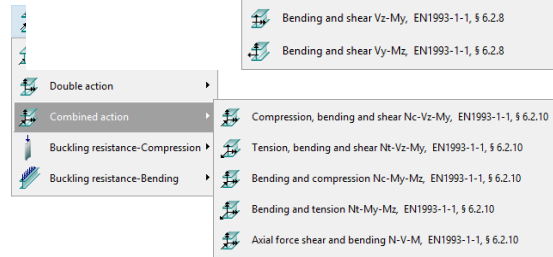
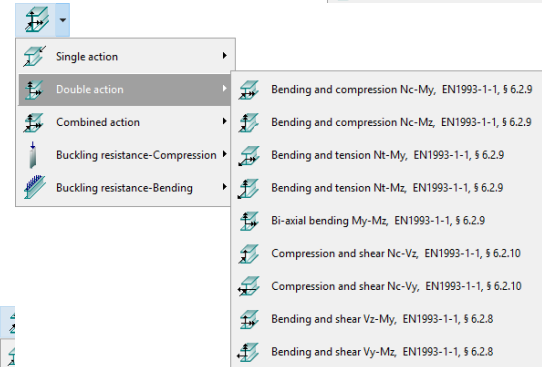
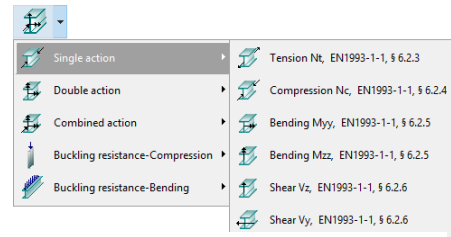

1. Select section group (standard, non- standard, welded)
2. From the tree on the left select the section.
3. Specify the design actions on the cross-section.

Detail report is obtained for the design of the selected cross-section under the specified loading. If the cross-section is not appropriate to resist the loading, error messages are displayed.



The screenshot shows the design of an IPE 180 section. The left panel displays a 3D model of the section with applied loads $M_{y,Ed}$ and $N_{c,Ed}$, and a 2D cross-section diagram with dimensions. The middle panel shows a list of sections, with IPE 180 selected. The right panel shows the design object 'STRENGTH-001' with the following properties:

- Structural steel grade (EN1993-1-1 §3.2): S 275 ($f_y=275N/mm^2$, $f_u=430N/mm^2$)
- Partial safety factors for actions: $\gamma_Q=1.35$, $\gamma_Q=1.50$, $\psi=0.90$
- Partial factors for materials: $\gamma_{M2}=1.00$, $\gamma_{M1}=1.00$, $\gamma_{M0}=1.25$
- Loading: $N_{c,ed}=130.00$ kN, $M_{y,ed}=43.00$ kNm
- Selected section: IPE 180
- Cross-section: IPE 180-S 275
- Dimensions of cross section:
 - Depth of cross section: $h=180$ mm
 - Width of cross section: $b=130$ mm
 - Web depth: $h_w=160$ mm
 - Depth of straight portion of web: $d_{st}=160$ mm
 - Web thickness: $t_w=5.30$ mm
 - Flange thickness: $t_f=8.00$ mm
 - Radius of root fillet: $r=9.00$ mm
 - Mass: $m=18.80$ Kg/m
- Properties of cross section:
 - Area: $A=2395$ mm²
 - Second moment of area: $I_y=1.317E007$ mm⁴, $I_z=1.009E006$ mm⁴
 - Section modulus: $W_y=146300$ mm³, $W_z=22160$ mm³
 - Plastic section modulus: $W_{py}=166400$ mm³, $W_{pz}=34600$ mm³
 - Radius of gyration: $i_y=74$ mm

13 Buckling resistance of members (Eurocode 3, EN1993-1-1:2005 § 6.3)

13.1 Uniform members in compression EN1993-1-1:2005 § 6.3.1

13.1.1 Columns with axial load only

1. Select section group
2. From the tree on the left select the section.
3. Specify the design actions. Axial load $N_{c,ed}$ [kN].
4. Specify the member length L in meters, and the buckling lengths in y-y and z-z direction. The buckling lengths are specified by the ratios to the member length. The ratios may be selected from the standard buckling lengths by click at  or from the buckling lengths of frame columns by clicking at  or  for braced or unbraced frames according to Eurocode 3.

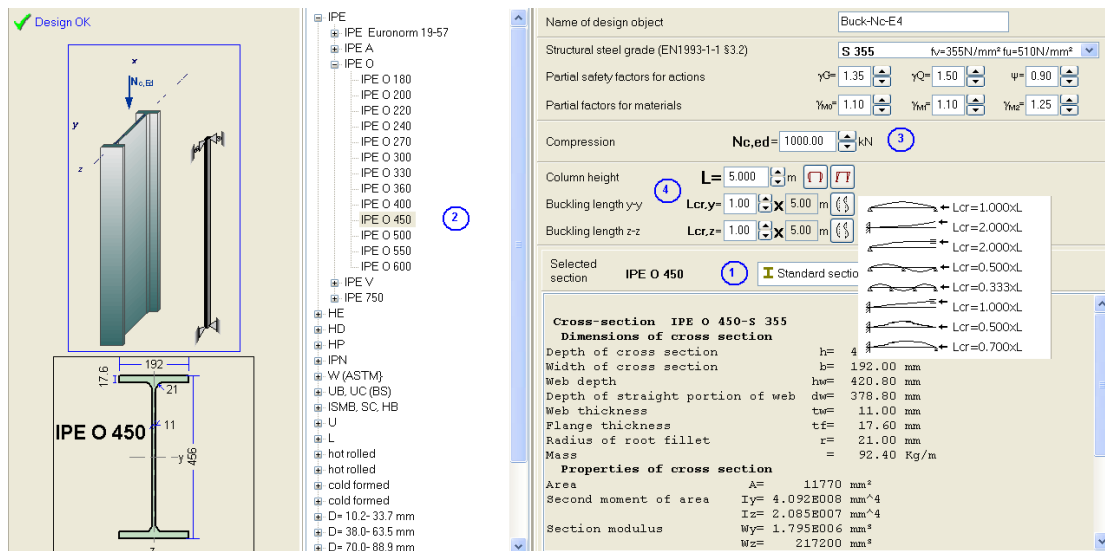
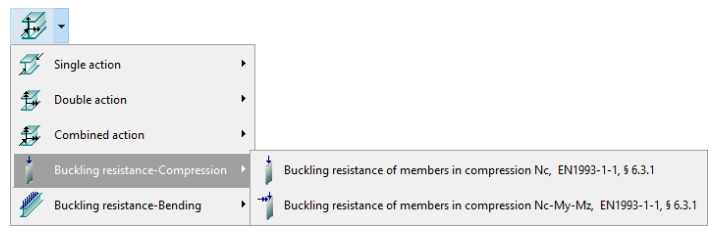

13.2 Uniform members in bending EN1993-1-1:2005 § 6.3.2

13.2.1 Beams with vertical load only

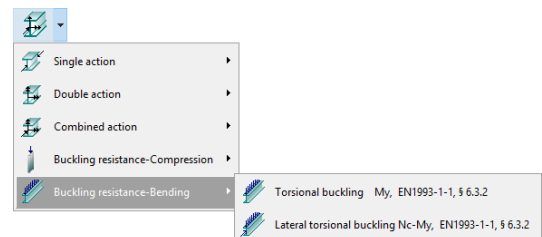

1. Select section group
2. From the tree on the left select the section.
3. Specify the beam loading as a combination of uniform [kN/m] and concentrated [kN] loads. For concentrated loads specify the distance x [m] from left support. The loads are for permanent and live loading conditions.
4. Specify the end support conditions of the beam (simply supported, fixed at one end or fixed at both ends).
5. Specify the member length L in meters, and the lateral buckling length L_c [m]. The lateral buckling length is the distance of lateral supports.

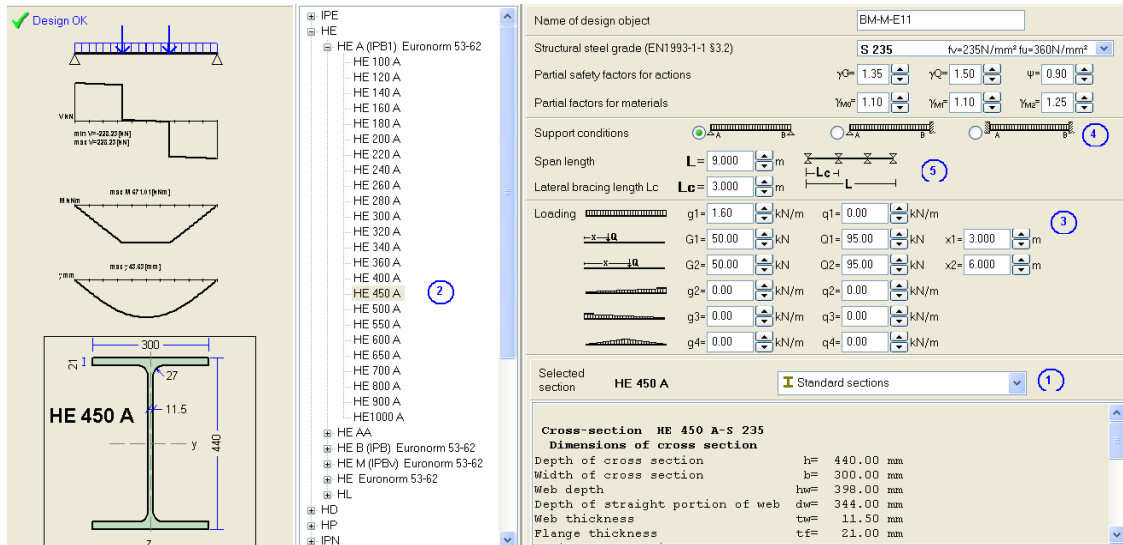



13.3 Uniform members in bending and axial compression, (EN1993-1-1:2005 § 6.3.3)

13.3.1 Columns with axial compression and end moments

1. Select section group
2. From the tree on the left select the section.
3. Specify the column axial load N_g [kN] (permanent) and N_q [kN] (live).
4. Specify the column end moments at top point A and bottom point B. Moments M_{yy} [kNm] for the bending around the main axis and M_{zz} [kNm] for bending around the secondary axis. Moments M_{yyAg} , M_{zzAg} , M_{yyBg} , M_{zzBg} for permanent loading and M_{yyAq} , M_{zzAq} , M_{yyBq} , M_{zzBq} for live loading.
5. Specify the member length L in meters.
6. Specify the buckling lengths in y-y and z-z direction. The buckling lengths are specified by the ratios to the member length. These ratios may be selected from the standard buckling lengths by click at  or from the buckling lengths of frame columns by clicking at  

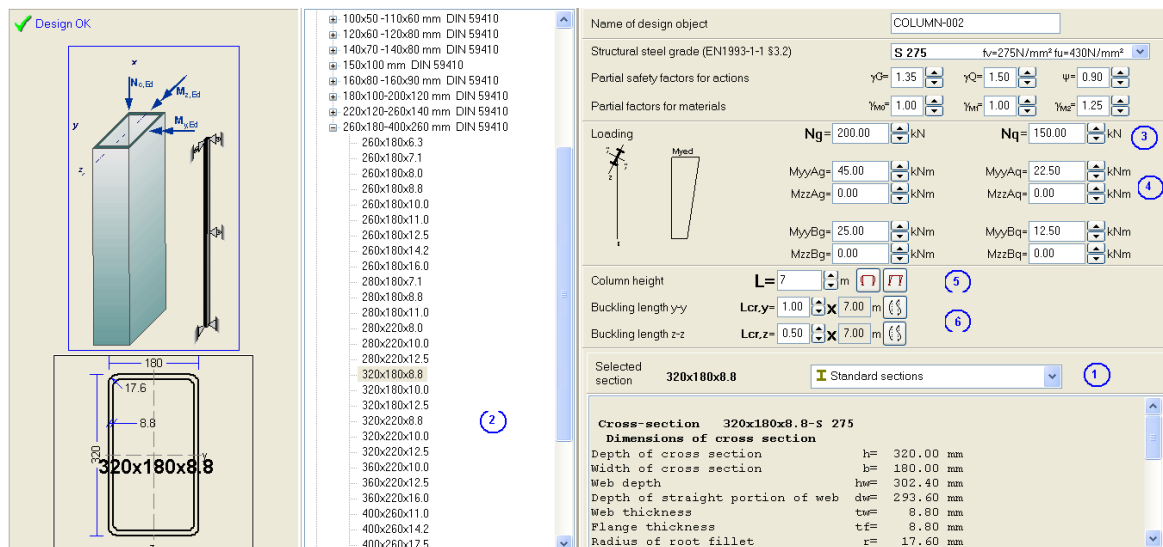

13.3.2 Beams with vertical load and axial compression

1. Select section group
2. From the tree on the left select the section.
3. Specify the axial load of the beam N_g [kN] permanent, N_q [kN] live load.
4. Specify the beam loading as a combination of uniform [kN/m] and concentrated [kN] loads. For concentrated loads specify the distance x [m] from left support. The loads are for permanent and live loading conditions.
5. Specify the end support conditions of the beam.
6. Specify the member length L in meters, and the lateral buckling length L_c [m]. The lateral buckling length is the distance of lateral supports.

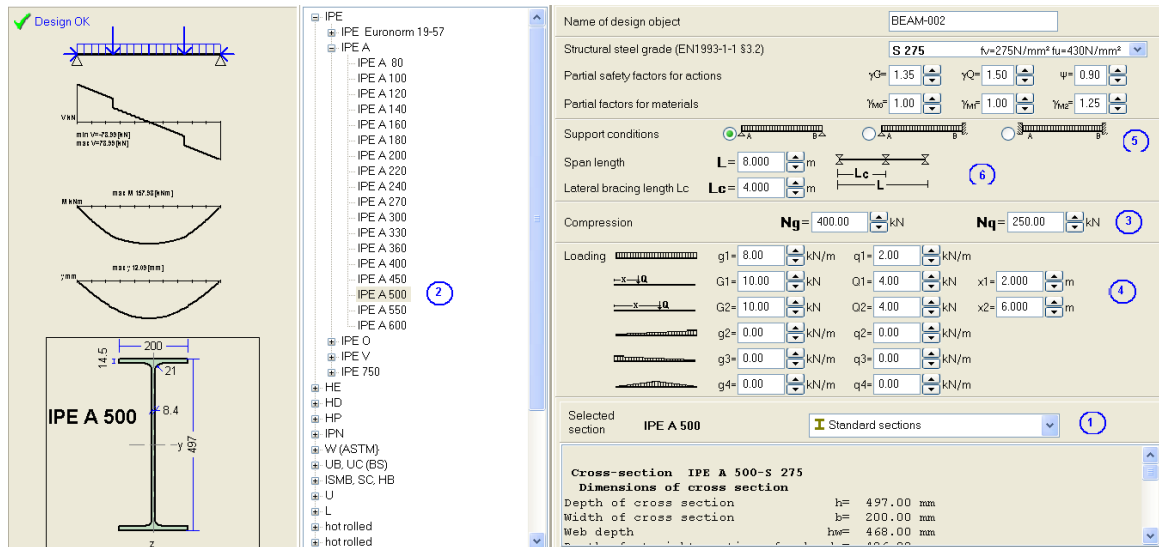

14 Connections EN1993-1-8:2005

Design of various connections. For most types of connections there is

1. Connection design, Specify the connection loading and the program selects optimum connection geometry and bolt arrangement to satisfy the design of the connection.
2. Connection capacity, you specify the connection geometry and the bolt arrangement, and the capacity of the connection is evaluated

14.1 Connection types

14.1.1 Tension connections (design and capacity)

- shear joint
- double shear joint
- splice joint
- chord continuity I sections
-

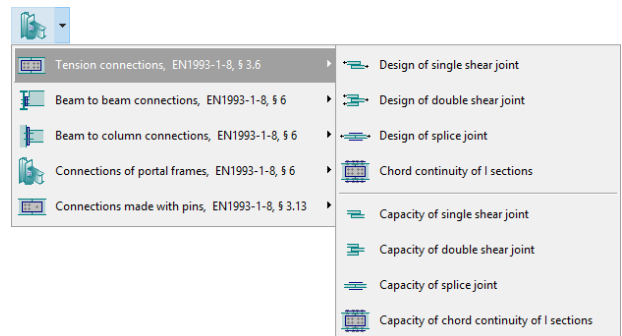

14.1.2 Beam to beam connections (design and capacity)

- Beam-continuation connection
- Gerber-beam connection
- Beam-on-beam connection with web cleats

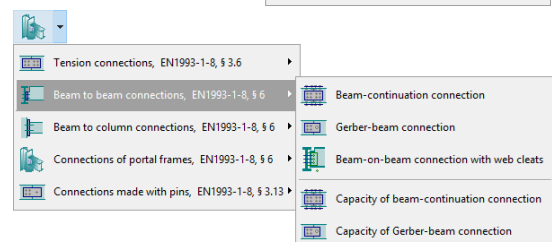

14.1.3 Beam to column connections

- Beam on column connection with web cleats
- Beam on column connection with end plates

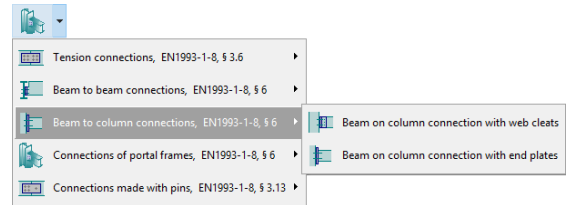

14.1.4 Connections of portal frames

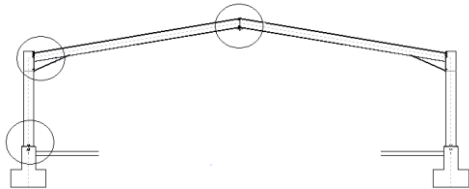

Bolted connections with end or base plate.

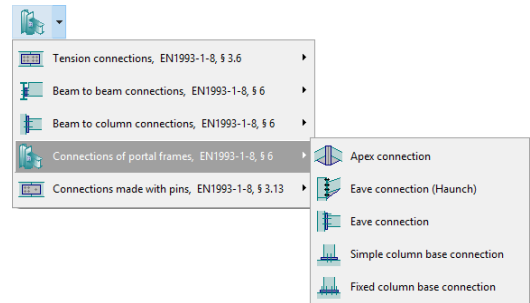

• **Apex connection**

Usual loading with positive bending moment, the bottom of the connection is in tension. A small haunch is provided at the bottom to increase the lever arm for the tension bolts.

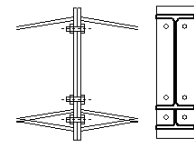

• **Eave connection with haunch**

• **Eave connection without haunch**

For connections with high bending moment a haunch is provided to increase the level arm of the bolts in tension. The height of the haunch is assumed the same as the height of the connected rafter beam. A compression stiffener is provided in the column at the bottom of the connection to take the increased compressive forces.

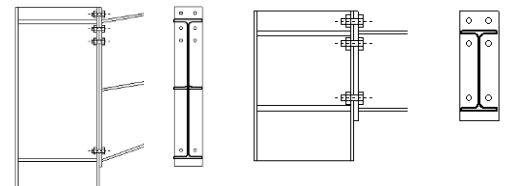

• **Simple column base connection,**
• **Fixed column base connection**

The connection has a base plate connected to the column by fillet welds. Holding down anchoring bolts are designed. The bolts are anchored in the concrete foundation with hooks or washer plates. If the connection is simple connection then the connection is not designed to carry bending moment. (pin connection). In the case of pin connection the bolts are located in the middle of the column. If the connection is designed to carry bending moment (fixed connection), the bolts are located outside and close to the peripheral of the column.

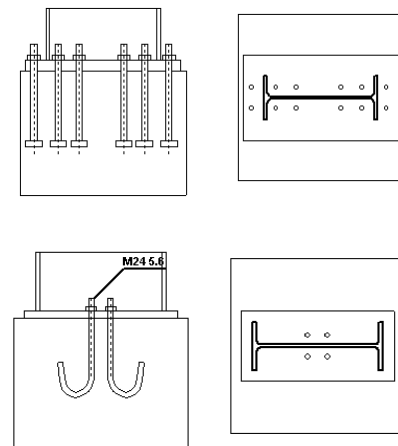

14.1.5 Connections made with pins (design and capacity)

- Pin ended member
- Gerber-beam connection

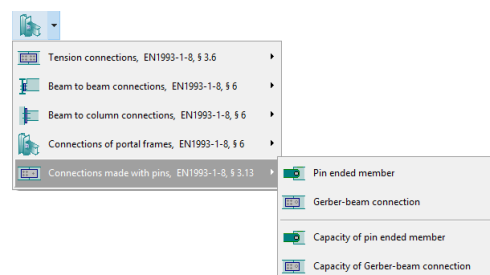

14.2 Connection data

14.2.1 Connection loading

Design forces and moments on the connected members as the drawing shows.

14.3 Connection bolts EN1993-1-8 §3.1

- Diameter of bolts in mm M (from 8 to 30 mm)
- Grade of bolts. (From 4.6 to 10.9) according to EN1993-1-8 Tab3.1.
- Regular or preloaded bolts (only for bolts of grades 8.8 and 10.9) EN1993-1-8 §3.1.2. In case of preloaded bolts give the values of K_s , μ , γ_{M3} according to EN1993-1-8 §3.9.1
- Shear plane through the treated part or not. EN1993-1-8 Tab 3.4.

Bolts (EN1993-1-8 §3.1)		<input type="radio"/> Regular bolts <input checked="" type="radio"/> Preloaded bolts	
Bolts, diameter, strength grade	M 22	Grade	10.9
Shear plane of bolt (EN1993-1-8 §3.5)	<input type="radio"/> through the threaded portion <input checked="" type="radio"/> through the unthreaded portion		
Slip-resistance connection	$k_s = 1.00$	$\mu = 0.50$	$\gamma_{M3} = 1.25$

Loading	Nc.ed = 400.00 kN
---------	-------------------

14.4 Connection plates

Dimensions of the connection plates are given in mm.

Connected plates	
Plate-1, width b and thickness t	b1 = 240 mm t1 = 10 mm
Plate-2, width b and thickness t	b2 = 240 mm t2 = 8 mm

14.5 Joint geometry

In case of evaluating the capacity of a joint, the number and positioning of the bolts has to be chosen. The basic distances between the bolts have to be specified.

In the case of designing a connection for a given load, the program selects the optimum geometry and the necessary number of bolts.

The distances from the edges and between the bolts are according to EN1993-1-8 Tab 3.3 and Fig. 3.1

Joint type				
Edge distances of bolts	$e1=ex = 55$ mm	$e2=ey = 50$ mm		
Spacing of bolts	$p1=px = 113$ mm	$p2=py = 140$ mm		

15 Design of Steel Beams

15.1.1 Beams in Uniform load

- Beams of One span,
- Two spans or one span
- Beam with one span and cantilever.

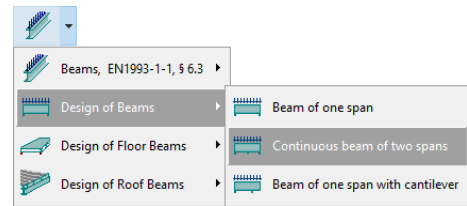

Beam loads

Uniformly distributed permanent and variable load in Kn/m. The program adds the beam self weight.

Beam loads				
Permanent load (EN1991-1-1 §5.2)	gk1= 7.00	kN/m	gk2= 7.00	kN/m
Variable load (EN1991-1-1 §6.3)	qk1= 8.00	kN/m	qk2= 8.00	kN/m

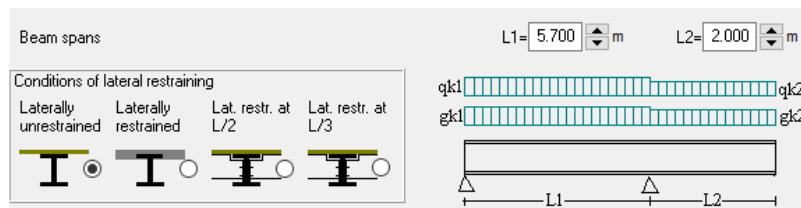

Beam span and lateral restrains

Beam span L in Meters

Conditions of lateral restrains, laterally unrestrained, laterally totally restrained, and laterally restrained in middle span or at one third span.

15.2 Design of floor beams

- Floor of one span
- Floor of two spans

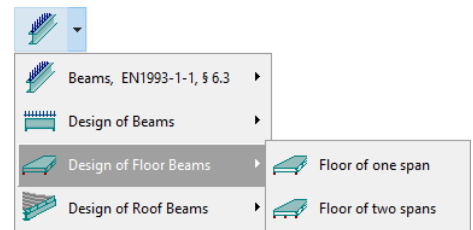

Floor loads

- Weight of floor finishing, the weight of the floor finishing (tiles etc.)
- Weight of floor structure then weight of the floor structure. If you select thin concrete slab (70mm) or timber floor. The floor beams are checked as unrestrained. For thicker concrete slab are checked restrained, and for steel floor (steel plates etc) are checked later restrained at one middle point. The lateral restraining selection can be altered afterwards
- Variable load. You can select from the table of EN1991-1-1 6.3).

Steel floor	0.70 kN/m ²
Concrete floor 70mm	1.75 kN/m ²
Concrete floor 100mm	2.50 kN/m ²
Concrete floor 150mm	3.75 kN/m ²
Concrete floor 200mm	5.00 kN/m ²
Concrete floor 250mm	6.25 kN/m ²
Concrete floor 300mm	7.50 kN/m ²
Timber floor	0.30 kN/m ²
Steel floor	0.70 kN/m ²

Beam span and lateral restrains

Beam spans (L) of main floor beams and beam spacing (s) in Meters.

Conditions of lateral restrains, laterally unrestrained, laterally totally restrained, and laterally restrained in middle span or at one third span

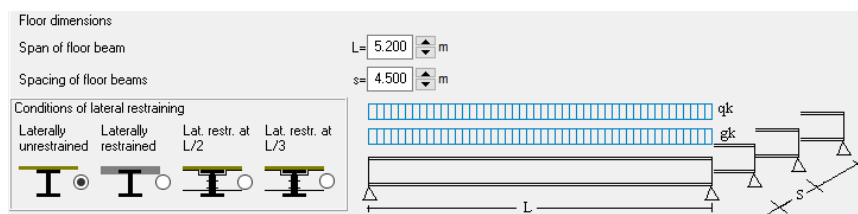

15.3 Design of Roof beams

- Roof beam of one and two spans
- Purlins

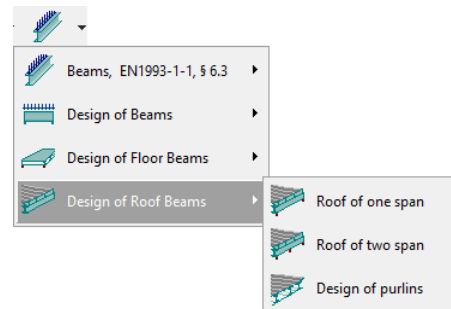

Dimensions

Main roof, beam spans and spacing. The Purlin span is equal to the beam spacing.

Roof dimensions	
Beam spans	L= 8.000 m
Spacing of beams	s= 5.200 m

Loads

Permanent loads

- Load of roof covering [kN/m²]
It includes the weight of the sheeting, purlins and insulation materials.
- Load of ceiling under the roof [kN/m²]
- self weight of beams, is calculated by the program from the beam cross sections with Unit mass $\rho = 7850 \text{ Kg/m}^3$

Roof loads		
Permanent load (EN1991-1-1 §6.3)	gk= 0.250 kN/m ²	Roof slope 10.00 °
Snow load (EN1991-1-3 §5.3)	qs= 3.043 kN/m ²	Sweden, Finland, z=3, A=100m, Sk=3.04kN/m ²
Wind load, pressure (EN1991-1-4 §7.2)	qwk(+)= 0.000 kN/m ²	Finland SFS-EN, Ub,0=26.00m/s
Wind load, suction (EN1991-1-4 §7.2)	qwk(-)= 0.900 kN/m ²	
Imposed load (EN1991-1-1 §6.3.4.2)	qk= 0.400 kN/m ²	

Variable loads

- Imposed load according to EN1990-1-1 Tab 6.1, calculated by the program according to the selected National Annex
- Snow load, according to Eurocode 1-3:2004
- Wind load, according to Eurocode 1-4:2005

15.4 Design of Purlins

The cladding is supported on purlins. The thickness of the sheeting t_w [mm] and the profile height h_w [mm] are used for estimating the degree of lateral restraint of the purlins.

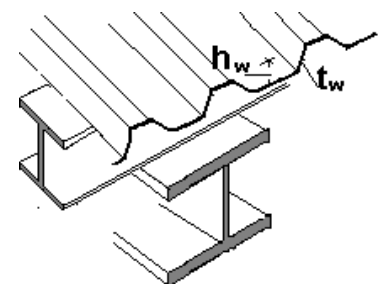

Purlins	
Purlin spacing	3.000 mm
Cladding(Sheeting)	Sheeting thickness $t_w = 0.75$ mm
	Profile depth $h_w = 40.0$ mm
	<input checked="" type="radio"/> Simply supported purlin <input type="radio"/> Continuous purlin <input type="radio"/> Purlin laterally unrestrained <input checked="" type="radio"/> Purlin laterally restrained

The spacing of purlins is the distance between the purlin axes. The section of purlins can be a symmetric section (I) or a non symmetric Z, C or U section. In the case of non symmetric purlin section the purlin is considered laterally restrained completely for downwards loading (sagging).

If you select *purlin laterally unrestrained* then the possible restraining of the purlin due to sheeting is disregarded. If you select *purlin laterally restrained* then the restraining due to sheeting is evaluated and used for wind pressure (sagging). The purlin is considered laterally unrestrained for wind uplift (hogging).

For the evaluation of the dimensioning bending moments and shear forces you may choose *Simply supported purlin* or *Continuous purlin*. In the second case the purlin is considered continuous over many spans.

16 Design of Steel Columns

16.1 Column design

- Columns in axial load
- Columns in Axial load and simple bending
- Columns in Axial load and double bending

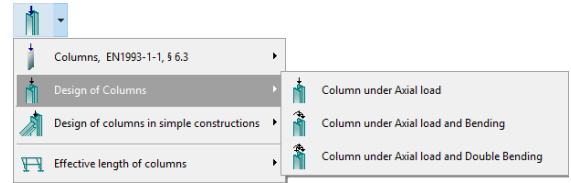

Loading

Loading	Permanent load (EN1991-1-1 §5.2)	$N_g = 625.00$ kN	$M_{yg} = 40.00$ kNm	$M_{zg} = 20.00$ kNm
	Variable load (EN1991-1-1 §6.3)	$N_q = 360.00$ kN	$M_{yq} = 20.00$ kNm	$M_{zq} = 10.00$ kNm

Axial load in (kN) and bending moments in (kNm) in the two bending directions. Y-y is the main bending direction, z-z is the secondary bending direction. Permanent and variable load.

Column height and buckling lengths

Column height	$L = 3.400$ m	<input type="checkbox"/> <input checked="" type="checkbox"/>	EC3 (§6.3.2.2)	EC3 (§6.3.3)
Buckling length y-y	$L_{cr,y} = 2.00$ x 3.40 [6.80] m	<input type="checkbox"/> <input checked="" type="checkbox"/>	<input type="radio"/> EC3-Eq.6.56	<input type="radio"/> Method 1
Buckling length z-z	$L_{cr,z} = 1.00$ x 3.40 [3.40] m	<input type="checkbox"/> <input checked="" type="checkbox"/>	<input checked="" type="radio"/> EC3-Eq.6.57	<input checked="" type="radio"/> Method 2
Buckling lengths, In-plane buckling		Buckling lengths, Out-of-plane buckling		

Column height and buckling lengths in the two bending directions, y-y and z-z. The buckling lengths are specified by the ratios to the column length. The ratios may be selected from the standard buckling lengths by click at or from the buckling lengths of frame columns by clicking at for braced or unbraced frames according to Eurocode 3.

Eurocode 3 options

You can select the lateral buckling curves of Eq 6.56 or Eq. 6.57. You can select the method (1 or 2 or both) for computing the interaction factors K_{yy}, k_{yz}, k_{zy} and k_{zz} .

16.2 Columns in simple constructions

- Simple column
- Column in Braced frames
- Column in unbraced frames

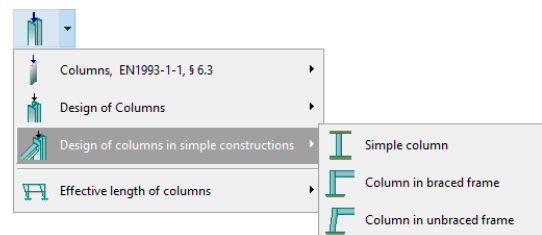

17 Design of single-bay steel portal frames

- **Single bay Portal frame under snow, wind and seismic load.** (common in portal frame for industrial buildings)
- **Single Bay portal frame under vertical and horizontal load.** (common in portal frame of one floor buildings)
- **Single Bay portal frame under vertical and horizontal load with concentrated loads on the columns.** (common in portal frame in buildings with many floors)

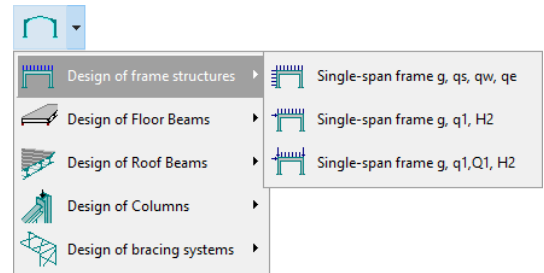

17.1 Basic structure dimensions

- Bay width L [m], the distance between column axes.
- Total height H [m] column height at axis points.
- Total transverse length B [m].
- Spacing s [m] of frames, transverse distance of column axis.
- Type of support. Pinned or fixed.
- The spacing of the lateral bracing for columns and torsional bracing for rafters is used for the lateral-torsional buckling design.

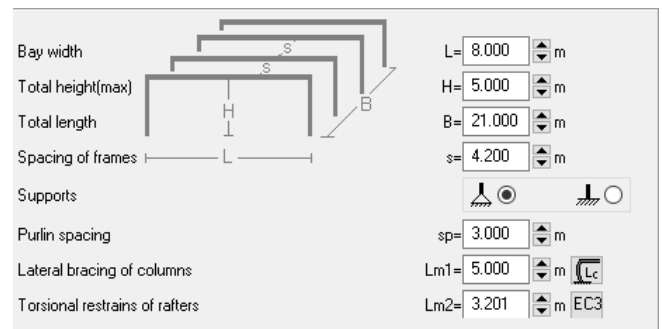

17.2 Design parameters for buckling control

Select the way they apply the lateral bracing. By clicking at  you define the lateral support of the columns and rafters.

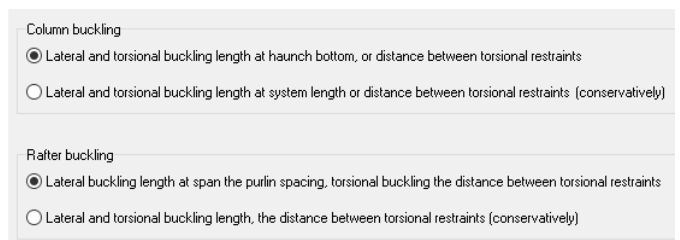

Column buckling

(1): (most reasonable default)

- In plane buckling, critical buckling length L_{cr} =system length points of axis.
- Out of plane buckling and torsional buckling and lateral torsional buckling, critical buckling L_{cr} the column height up to the haunch, or the distance of lateral restrains L_{m1} , if is specified smaller than the column length.

(2): (conservatively)

- In plane buckling L_{cr} =system length points of axis.
- Out of plane buckling and torsional buckling and lateral torsional buckling, L_{cr} the system length or the distance of lateral restrains L_{m1} .

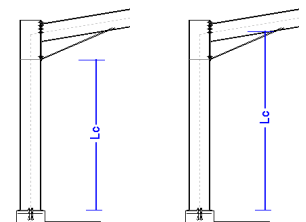

Rafter buckling

(2) (most reasonable default)

- In plane buckling L_{cr} =system length. This s computed from the total span L and the first buckling mode.
- Lateral buckling length at span the purlin space, torsional buckling the distance between torsional restraints L_{m2}

(2) (conservatively)

- In plane buckling L_{cr} =system length
- Lateral and torsional buckling length, the distance between torsional restraints L_{m2} .



17.3 NAD parameters

Click **EC3** to see and adjust (if needed) the Eurocode 3 and National Annex parameters

Action coefficients for Ultimate limit states EQU and STR.

According to Eurocode 0 Tables A1 2A and A1 2B. Click Reset to reset to National Annex values.

Load Combination coefficients according to Eurocode0 Table A1.1.

Action	ψ_0	ψ_1	ψ_2
Category A (domestic and residential areas)	0.70	0.50	0.30
Category B (office areas)	0.70	0.50	0.30
Category C (common areas)	0.70	0.70	0.60
Category D (shopping areas)	0.70	0.70	0.60
Category E (storage areas)	1.00	0.90	0.80
Category F (parking areas light <=35kN)	0.70	0.70	0.60
Category G (parking areas medium 35kN < <=160kN)	0.70	0.50	0.30
Category H (roofs)	0.00	0.00	0.00
Snow loads on buildings (H>100 m.a.s.l.)	0.70	0.50	0.20
Snow loads on buildings (H<=100 m.a.s.l.)	0.50	0.20	0.00
Wind loads on buildings	0.60	0.20	0.00

Material factors for Steel according to Eurocode 3 §6.1

Reinforced concrete according to Eurocode 2 §2.4.2.4., used for the reinforced concrete in the foundation.

Eurocode 3, design parameters.

Lateral torsional buckling computations base on Eurocode 3 Eq. 6.56, and Tables T 6.3, and T 6.4. (most common)

Lateral torsional buckling computations base on Eurocode 3 Eq. 6.57, and Table T 6.5.

Method for Bending and compression.
Method 1 Annex A or method 2 Annex B (most common)

Source for computing elastic critical moment for lateral buckling.

Parameters for Portal frames

Specify some parameters that are not covered from national annex. Such as:

Deflection limits for Serviceability limit state (SLS)

The limits for these deflections are usually defined in the National Annex. EN1993-1-1 § 7.2 and EN 1990 Annex A1.4 According to EN1993-1-1 these limits may be specified for each project and agree with the client. Usual values: vertical deflection L/200, horizontal deflection H/150, vertical deflection due to bending L/200.

ULS (EQU) EC0 EN1990:2002 §6.4 Tab.A1.2A
 Action coefficient for permanent loads, unfavourable $\gamma_{G, sup} = 1.10$
 Action coefficient for permanent loads, favourable $\gamma_{G, inf} = 0.90$
 Action coefficient for variable loads, unfavourable $\gamma_Q = 1.50$
 ULS (STR) EC0 EN1990:2002 §6.4 Tab.A1.2B
 Action coefficient for permanent loads, unfavourable $\gamma_{G, sup} = 1.35$
 $\xi = 0.650$
 Action coefficient for permanent loads, favourable $\gamma_{G, inf} = 1.00$
 Action coefficient for variable loads, unfavourable $\gamma_Q = 1.50$

Eurocode 3 (Steel structures) EC3 EN1993-1-1:2005 §6.1
 $\gamma_{M0} = 1.00$ $\gamma_{M1} = 1.00$ $\gamma_{M2} = 1.25$
 Eurocode 2 (Reinforced concrete) EC2 EN1992-1-1:2004 §2.4.2.4
 $\gamma_c = 1.50$ $\gamma_s = 1.15$
 Eurocode 7 (Geotechnical design) EC7 EN1997-1-1:2004 Annex A
 $\gamma_{qU}(EQU, GEO) = 1.40$ $\gamma_q(EQU, GEO) = 1.25$

Lateral torsional buckling (EN1993-1-1 §6.3.2.3)
 Method of computation:
 EC3-Eq 6.56 EC3-Eq 6.57
 $\bar{\lambda}_{LT,0} = 0.40$ $\beta = 0.75$
 Bending and compression (EN1993-1-1 §6.3.3)
 Method of computation:
 Method 1 Method 2 Method 1 and 2

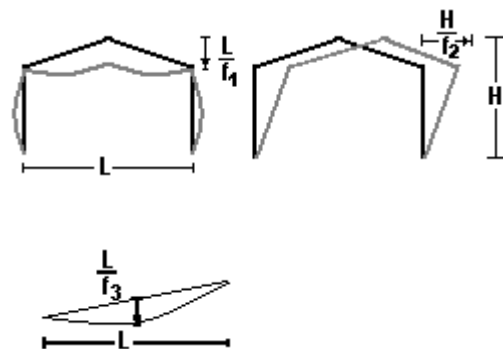

Limit for vertical deflection $w \leq L/f1$ $f1 = 200.0$
 Limit for horizontal deflection $u \leq H/f2$ $f2 = 150.0$
 Maximum roof deflection in general $w_{max} \leq L/f3$ $f3 = 200.0$
 Roof deflection due to variable action $w3 \leq L/f4$ $f4 = 250.0$
 Limit roof slope, to consider snow and wind load as for flat frame $\alpha \leq 2.0$
 Column buckling
 Lateral and torsional buckling length at haunch bottom, or distance between torsional restraints
 Lateral and torsional buckling length at system length or distance between torsional restraints (conservatively)
 Rafter buckling
 Lateral buckling length at span the purlin spacing, torsional buckling the distance between torsional restraints
 Lateral and torsional buckling length, the distance between torsional restraints (conservatively)

17.4 Cross-sections

I	h	b	tw	tf	r	A	G	ly	Wy	Wply	ly	Av,z	Iz	Wz	Wplz	iz	Av,y	It	Iw
	mm	mm	mm	mm	mm	cm ²	Kg/m	cm ⁴	cm ³	cm ³	cm	cm ²	cm ⁴	cm ³	cm ³	cm	cm ²	cm ⁴	cm ⁶
I 180	80	42	3.9	5.9	3.9	7.57	5.94	77.80	19.50	22.70	3.21	3.30	6.29	3.00	5.46	0.912	4.96	0.798	100.0
I 1100	100	50	4.5	6.8	4.5	10.60	8.34	171.0	34.20	39.70	4.02	4.72	12.20	4.88	8.94	1.07	6.80	1.47	307.6
I 1120	120	58	5.1	7.7	5.1	14.20	11.1	328.0	54.70	63.50	4.81	6.45	21.50	7.41	13.63	1.23	8.93	2.49	789.4
I 1140	140	66	5.7	8.6	5.7	18.20	14.3	573.0	81.90	95.20	5.61	8.32	35.20	10.70	19.73	1.39	11.35	3.96	1.779
I 1160	160	74	6.3	9.5	6.3	22.80	17.9	935.0	117.0	136.0	6.40	10.54	54.70	14.80	27.41	1.55	14.06	6.01	3.633
I 1180	180	82	6.9	10.4	6.9	27.90	21.9	1.450	161.0	187.0	7.21	13.00	81.30	19.80	36.86	1.71	17.06	8.76	6.873
I 1200	200	90	7.5	11.3	7.5	33.40	26.2	2.140	214.0	249.0	8.00	15.60	117.0	26.00	48.26	1.87	20.34	12.96	12.222
I 1220	220	98	8.1	12.2	8.1	39.50	31.1	3.060	278.0	323.0	8.80	18.55	162.0	33.10	61.79	2.03	23.91	16.97	20.659
I 240	240	106	8.7	13.1	8.7	46.10	36.2	4.250	354.0	411.0	9.60	21.75	221.0	41.70	77.64	2.19	27.77	22.76	33.469
I 1260	260	113	9.4	14.1	9.4	53.30	41.9	5.740	442.0	513.0	10.38	25.41	288.0	51.00	95.14	2.32	31.87	30.52	51.258
I 1280	280	119	10.1	15.2	10.1	61.00	47.9	7.590	542.0	631.0	11.15	29.43							
I 1300	300	125	10.8	16.2	10.8	69.00	54.2	9.800	653.0	761.0	11.92	33.75							
I 1320	320	131	11.5	17.3	11.5	77.70	61.0	12.510	782.0	913.0	12.69	38.34							
I 1340	340	137	12.2	18.3	12.2	86.70	68.0	15.700	923.0	1.078	13.46	43.26							
I 1360	360	143	13.0	19.5	13.0	97.00	76.1	19.610	1.090	1.274	14.22	48.83							
I 1380	380	149	13.7	20.5	13.7	107.0	84.0	24.010	1.260	1.480	14.98	54.34							
I 1400	400	155	14.4	21.6	14.4	118.0	92.4	29.210	1.460	1.712	15.73	60.37							
I 1425	425	163	15.3	23.0	15.3	132.0	104.0	36.970	1.740	2.041	16.74	67.58							
I 1450	450	170	16.2	24.3	16.2	147.0	115.0	45.950	2.040	2.394	17.66	76.19							
I 1475	475	178	17.1	25.6	17.1	163.0	128.0	56.480	2.380	2.795	18.61	85.00							
I 1500	500	185	18.0	27.0	18.0	179.0	141.0	68.740	2.750	3.235	19.60	93.68							
I 1550	550	200	19.0	30.0	19.0	212.0	166.0	99.180	3.610	4.229	21.63	109.1							
I 1600	600	215	21.6	32.4	21.6	254.0	199.0	139.000	4.630	5.465	23.39	135.7							

Specify the cross section for the columns, the rafters. Select if you use Standard section profiles, Non-standard or fabricated (welded) sections). The sections are from the library of sections of the program. In which you specify the properties for the non-standard sections as well as you make the welded sections.

All the standard hot- rolled or cold-format cross sections are included.

Click the library with the section appears to select section profile. You select the section type on the left tree and at the same time all the sections of this group with their geometric properties are displayed on the right window together with the section drawing in scale.

Section geometric properties are calculated precisely including fillets.

The notation is shown at the drawing at the low left window.

17.5 Estimate of member sizes

Click and you get a rough estimate of member sizes for the structural elements of the structure with the dimensions you have specified. You can start with this estimate to continue for better design.

17.6 Portal frame Connections

Apex and eave bolt-connections with end plate are designed to resist moment and shear forces. For the apex and eave connection the end plate (thickness and steel grade) and bolts (diameter, grade) are the same. The thickness of Apex and eave end plate should be at least as thick as the flange thickness of the rafter and column section. At the base of the haunch, a stiffener is designed to resist the increased compressive forces.

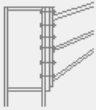
Connections: EN1993-1-8	<input checked="" type="checkbox"/> Design of connections	
End Plate (eave, apex)	Thickness tp= 20 mm	S 235
Bolts, diameter, strength grade	M 20	10.9 Bolt strength grade
Base Plate	Thickness tb= 30 mm	S 235
Anchor bolts	M 20	5.6 Bolt strength grade
Concrete-Steel class	C25/30 - B500C	

Base plate bolt-connection is designed for the column over the concrete foundation. The anchor bolts are designed to resist shear and pullout forces due to uplift wind or seismic forces. CEN/TS 1992-4-1:1992 and CEN/TS 1992-4-2:1992 are used for the design of the fastenings in concrete

The holding down *anchor bolts* of the base plate are extended with anchors. The anchor system can be (simple hook, bended hook or washer plate). The hook type anchoring (first two choices) cannot be selected for bolt grade with $f_y > 300 \text{ N/mm}^2$ ($M > 5.6$), according to Eurocode 1993-1-8:2005, 6.2.6.12 (6). Anchor bolts with hook have much lower capacity of anchors with washer plate.

The design of connections is skipped if Design of connections is unchecked. The design of connections is skipped automatically if hollow cross section is selected.

If in the design process the base plate thickness or the bolt diameter is not adequate the program adjust them (if possible) to new higher values if the boxes next to them are not checked. Connections are designed according to EN1993-1-8.

17.7 Portal frame loading

17.7.1 Single Bay portal frame under snow, wind and seismic load

The program automatically forms and evaluates all the load combinations in ultimate limit state ULS (EQU, STR), and serviceability limit state SLS. The partial factors for loading and load combination factors are taken according to Eurocode 0 and National Annex. The basic loads are:

Loads: EN1991-1-1, EN1998-1-1		
Snow load on the ground (EN1991-1-3 §4)	Sk= 0.689 kN/m ²	IBR, z=4, A=100m, Sk=0.00kN/m ² , Ce=1.00, Ct=
Wind pressure on vertical surface (EN1991-1-4 §4)	qwk= 0.900 kN/m ²	Finland SFS-EN
Wind internal pressure (EN1991-1-4 §7.2.9)	wi=Cpi qwk= 0.000 kN/m ²	
Load of roof covering (EN1991-1-1)	gk1= 0.200 kN/m ²	
Load of ceiling under the roof	gk2= 0.000 kN/m ²	
Seismic loading (EN1998-1-1)	$\alpha = \alpha_{gr}/g$ 0.040	Europe, Seismic zone: 0, agr/g=0.040

Permanent loads

- Load of roof covering [kN/m²]
It includes the weight of the sheeting, purlins and insulation materials.
- Load of ceiling under the roof [kN/m²]
- self weight of frame elements, calculated by the program from the element cross sections with Unit mass $\rho = 7850 \text{ Kg/m}^3$

Variable loads

- Imposed load according to EN1990-1-1 Tab 6.1, calculated by the program according to the selected National Annex
- Snow load according to Eurocode 1-3:2004



The characteristic snow load on the ground s_k is specified in kN/m^2 .

Click  and a special dialog window appears from where by entering the zone and the height above the sea level the characteristic snow load on the ground is computed according to Eurocode 1-3:2004, and the National Annex. The snow region can be selected from Parameters/snow load on the ground. The snow load on the roof is computed according to Eurocode 1-3:2003.

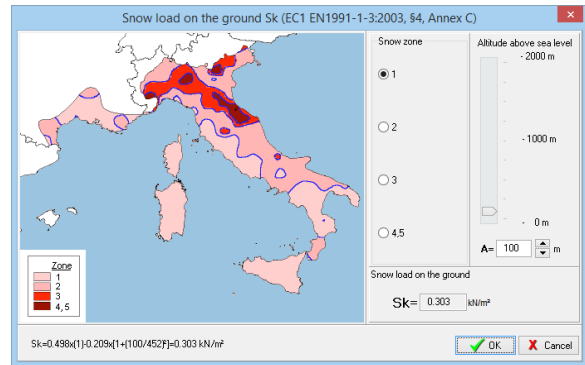

- Wind load, according to Eurocode 1-4:2005

The wind pressure on vertical surface is specified in kN/m^2 . Click  and a special dialog window appear from where you can compute the wind pressure from the wind velocity and the topography of the region according to Eurocode 1-4:2005. The wind load is computed for various places at the roof and the vertical walls according to Eurocode 1-4:2005 §7.2.5 and Tab 7.4a and Tab. 7.1.

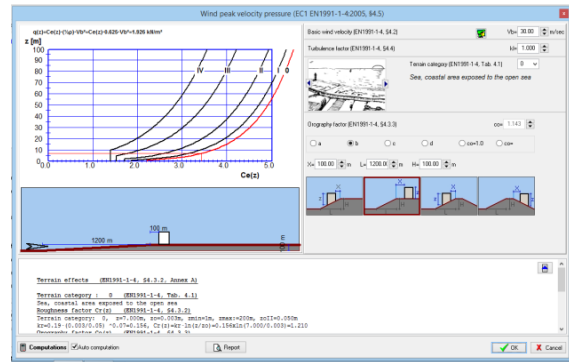

The wind region, which specifies the wind velocity, is selected from Parameters/Basic wind velocity.

Wind internal pressure w_i in kN/m^2 . This is internal pressure and it acts from inside outwards on the walls and roof. It is subtracted directly (without further multiplication by pressure coefficients) from any uplift wind pressure on the outside surfaces.

Seismic load Eurocode 8-1:2004

The program performs a verification of the structure under seismic loading, using both Lateral force method, and Modal superposition spectrum analysis. $\alpha = \alpha_{GR}/g$ 0.160

Basic value used in the seismic design is the ratio of horizontal seismic acceleration. Click  and a special dialog window appears where you may in detail specify all the necessary seismic parameters (soil factors, spectra periods, behaviour factors, etc.) for the design spectrum, according to Eurocode 8-1:2004.

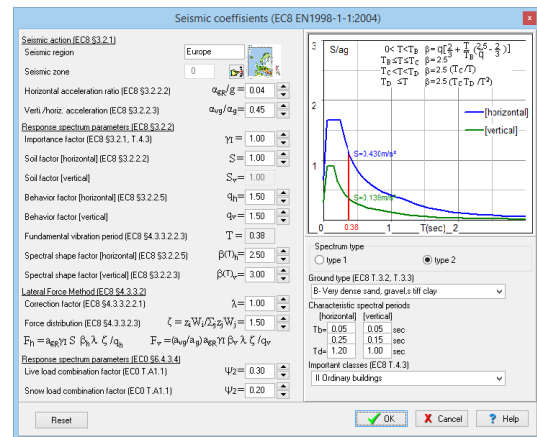

If seismic loading is specified 0 (zero), the seismic analysis is skipped.

17.7.2 Single Bay portal frame under vertical and horizontal load

- Permanent load g_k kN/m (total load except self weight of rafter)
- Variable load-1 vertical load q_k kN/m (imposed floor loads or snow load etc.)
- Variable load-2 concentrated Horizontal load H_k kN (wind or seismic load)
- The two variable loads q_k and H_k are combined if they act together with ψ_0 factor $\psi_0=0.70$
- The design loads obtained from load combinations as:

ULS (Ultimate limit state):
 $L.C. 201: 1.35g_k + 1.50q_k$ (Eq.6.10)



- L.C. 202: $1.35g_k+1.50H_k$ (Eq.6.10)
- L.C. 221: $1.35g_k+1.50q_k+0.70 \times 1.50H_k = 1.35xg_k+1.50q_k+1.05H_k$ (Eq.6.10)
- L.C. 222: $1.35g_k+1.50H_k+0.70 \times 1.50q_k = 1.35xg_k+1.50H_k+1.05q_k$ (Eq.6.10)
- SLS (Serviceability limit state)
- L.C. 301: G_k+Q_k (Eq.6.14a)
- L.C. 302: G_k+H_k (Eq.6.14a)
- L.C. 311: $G + Q_k + 0.70H_k$ (Eq.6.14a)
- L.C. 312: $G + H_k + 0.70Q_k$ (Eq.6.14a)

Loads			
Permanent load	gk=	2.100 kN/m	
Variable load-1	qk=	8.400 kN/m	
Variable load-2	Hk=	6.300 kN	

17.7.3 Single Bay portal frame under vertical and horizontal load with concentrated loads on the columns

- Permanent load gk kN/m (total load except self weight of rafter)
- Variable vertical load qk kN/m (imposed floor loads or snow load etc.)
- Permanent Concentrated load Gk kN (load from higher floors)
- Variable vertical concentrated load Qk kN (load from higher floors)
- Variable concentrated Horizontal load Hk kN (wind or seismic load)

Loads				
Permanent load	gk=	2.100 kN/m	Pgk= 16.800 kN	
Variable load-1	qk=	8.400 kN/m	Pqk= 67.200 kN	
Variable load-2	Hk=	6.300 kN		

18 Design of Bracing systems

Bracing systems are required to resist transverse actions, due to wind and earthquake. For this two bracing systems are provided.

Vertical bracing system in the sidewalls between the columns. This system transmits the horizontal transverse loads from the roof to the ground and temporary stability during the erection.

Horizontal roof bracing system. On the roof to transmit the transverse loads from the roof to the vertical bracing and to provide temporary stability during the erection.

For the vertical bracing system basic data are the dimensions length (Ly) and height H in meters, and the concentrated load on the top of the bracing system Qed2. For a structure with N bracings in the transverse direction and wind pressure wk (kN/m2), and wind pressure coefficients Cpe,D (pressure) on the upwind face and Cpe,E (suction) on the downwind face ,

$$Q_{ed2} = (1/4) \gamma_q \times (C_{pe,D} + C_{pe,E}) \times w_k \times A / N.$$

(A is the area of the face to the wind)

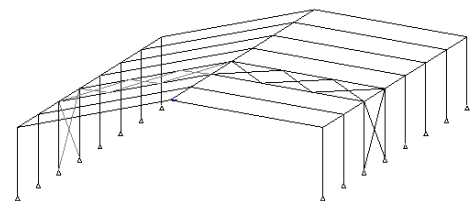
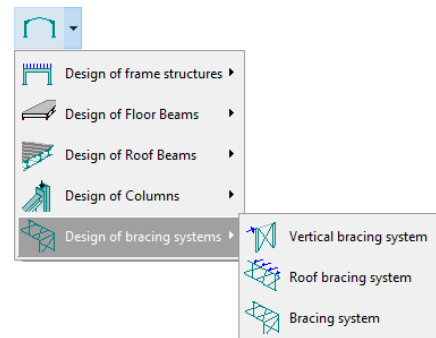

For the horizontal bracing system basic data are the length L_x and the width L_y and the load on the nodes Q_{ed1} . For a bracing system as above with k nodes

$$Q_{ed1} = \left(\frac{1}{2}\right) \gamma_Q \times (C_{pe,D} + C_{pe,E}) \times W_k \times A / (N \times (k-1))$$

For A general bracing system (vertical and horizontal) the loading is the uniform distributed load on the roof level q_{ed} .

$$q_{ed} = \left(\frac{1}{2}\right) \gamma_Q \times (C_{pe,D} + C_{pe,E}) \times W_k \times A / (N \times L).$$

18.1.1 Example

$W_k = 0.91 \text{ kN/m}^2$, $C_{pe,D} = 0.80$, $C_{pe,E} = -0.50$, $L = 24 \text{ m}$, $H = 6 \text{ m}$, $L_x = 6 \text{ m}$, $L_y = 8 \text{ m}$, $N = 3$, $k = 24/6 + 1 = 5$.

$$q_{ed} = \left(\frac{1}{2}\right) 1.50 \times (0.80 + 0.50) \times 0.91 \times (24 \times 6) / (3 \times 24) = 1.78 \text{ kN/m}$$

$$Q_{ed1} = \left(\frac{1}{2}\right) 1.50 \times (0.80 + 0.50) \times 0.91 \times (24 \times 6) / (3 \times 4) = q_{ed} \times L_x = 10.68 \text{ kN}$$

$$Q_{ed2} = \left(\frac{1}{4}\right) 1.50 \times (0.80 + 0.50) \times 0.91 \times (24 \times 6) / 3 = q_{ed} \times L / 2 = 21.36 \text{ kN}$$

The necessary number of connection bolts to connect the bracing members to the structure components are computed. You specify the desired bolt diameter and steel grade.

19 Fundamentals of Steel columns

The concrete footing of steel structures has to be designed to resist soil pressure for maximum vertical load, and it must have enough weight to resist uplift (from wind or seismic forces).

- Pin (N-H) and Fixed (N-H-M) Column foundations.
- You can also specify if the foundation has an horizontal tie to take the horizontal outwards forces or not

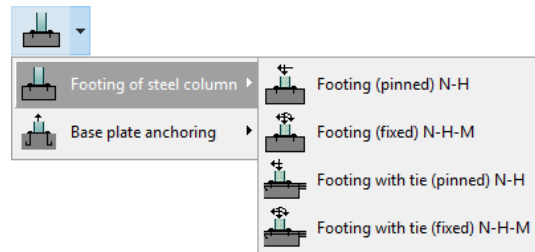

19.1 Loading on the fundament

The final design actions, after multiplication of permanent and variable loading with safety factors (γ_G and γ_Q), Eurocode 0-19990-1-1, Tabl.A1.2.

$$N_{ed} = \gamma_G \cdot N_{gk} + \gamma_Q \cdot N_{qk}$$

$N(-)_{ed}$ Axial load downwards.

$N(+),_{ed}$ Axial load upwards (uplift)

H_{ed} Horizontal force on the top of the base column. The height over the foundation surface of the base column ch must be specified for the correct application point of the horizontal force.



M_{ed} Moment at the top of the base column.

For download loading usual values are $\gamma_G = 1.35$ (unfavourable), $\gamma_Q = 1.50$.

For uplift loading usual value are $\gamma_G = 0.90$ (favourable), $\gamma_Q = 0.00$.

Structural steel grade [EN1993-1-1 §3.2]	S 355 $f_y=355\text{N/mm}^2$ $f_u=510\text{N/mm}^2$		
Partial safety factors for actions	$\gamma_G = 1.35$	$\gamma_Q = 1.50$	$\gamma_{G,inf} = 1.00$
Partial factors for materials	EC3 $\gamma_{M0} = 1.00$	$\gamma_{M1} = 1.00$	$\gamma_{M2} = 1.25$
Loading			
$N(-)_{ed} =$	175.00 kN	$H_{ed} =$	125.00 kN
$N(+),_{ed} =$	75.00 kN		
Concrete-Steel class	C25/30 - B500C Concrete cover $C_{nom} = 35$ mm X2		
Column Base	$c_x = 0.800$ m	$c_y = 0.800$ m	$ch = 2.000$ m
Footing	$B_x = 2.000$ m	$B_y = 2.000$ m	$B_h = 0.700$ m <input checked="" type="checkbox"/> $\varnothing 16$
Soil properties	$q_{uk} = 0.200$ N/mm ²	$\gamma_k = 20.00$ kN/m ³	$\phi_k = 35.00$ °
Footing depth	$h_f = 2.700$ m		

19.2 Dimensions of Fundament

The Dimensions of the fundament are B_x (length) , B_y (breadth) and B_h height. The dimensions of the base column are c_x,c_y and c_h . Select the concrete and steel classes, the concrete cover and the preferable diameter of steel reinforcement. Click   to select the concrete cover from environmental conditions according to Eurocode 2 4.2.

For the soil you specify the soil bearing capacity q_{uk} the soil unit weight γ_k and the angle of shearing resistance ϕ_k °.

You may obtain the soil properties from the table with soil properties .

The soil bearing capacity can be estimated by clicking .

19.3 Estimate of fundament dimensions (pre-dimensioning)

Click  to get a pre-dimensioning and a first estimate of the fundament dimensions. If

next to the fundament values B_x , B_y or B_h is checked $B_h=0.700$  m then this dimension value will not be changed in the pre-dimensioning. In pre-dimensioning the fundament dimensions are adjusted by the program so the fundament weight is enough to resist uplift forces. The width B_y and the height are also adjusted to be adequate so the passive earth force to resist the horizontal base force outwards

19.4 Steel Tie and Passive earth pressure

The high horizontal forces acting at the base are acting outwards as a result of bending in the columns due to vertical loading on the roof.

This is resisted in two ways:

- **Steel tie at column base** A tie cast into the floor slab connected to the base of the columns. This should be considered more safe method to resist the horizontal forces at the base of the columns
- **Passive earth pressure on the side of the foundation.** In this case the earth filling and compacting on the side of the foundation must be performed carefully, so that the passive earth pressure is not reduced. The fundament transverse width B_y and the height B_h are used to compute the active area for passive earth pressure.

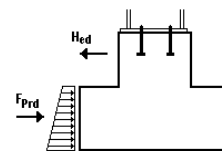
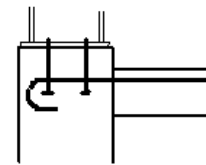

19.5 Foundation, Bearing resistance

The basis for the design of foundations is the bearing resistance of the soil. The design bearing resistance may be calculated using analytical or semi empirical methods. Annex D of Eurocode 7 EN1997:2004 describes a method of obtaining the design bearing strength of the soil.

The methods of Annex D for drained and undrained conditions are implemented in the program.

The Design bearing strength of the soil is estimated for EQU, STR and GEO conditions. The computation of design bearing strength is for drained and undrained soil conditions. For drain soil conditions the important soil property is the angle of shearing resistance ϕ_k [°] and the cohesion intercept c_k [kPA]. For undrained soil conditions the important soil property is the undrained strength c_u [kPa].

For the computation of design bearing strength other parameters are the dimensions and foundation depth of the footing, as well as the loading and the load eccentricities.

In the foundation design of the program for the soil strength we use the soil bearing pressure

quk (N/mm²). This is a corresponding soil strength to the soil allowable pressure. In the foundation design we use as Design bearing soil pressure $Q_{ud} = Q_{uk} / \gamma_{qu}$, where γ_{qu} is the partial factor for unconfined strength. (Eurocode 7, Annex A). So to be consistent the convert the design strength estimated from Annex D of Eurocode7 to the soil bearing pressure used in the program the design value have to be multiplied by γ_{qu} .

Is $\gamma_{qu} = 1.40$ for EQU and 1.00 and 1.4 for (STR-GEO).

Click , In the design of fundaments or in the design of retaining walls, and you get into a calculation window for design bearing resistance.

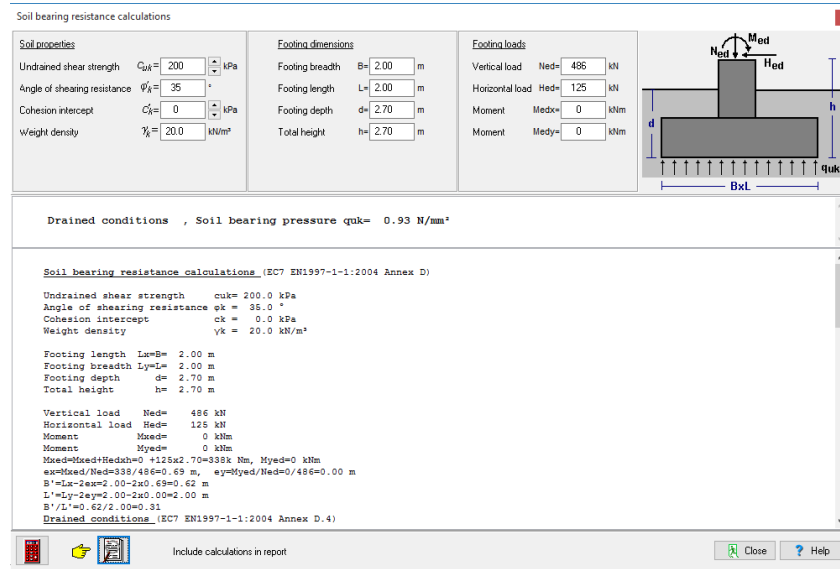

There you have an estimate of the soil bearing resistance Q_{uk} which you may use in the program, from the soil and fundament parameters.

If there you check to include the calculations in the report, then the design bearing resistance will be set to the minimum estimated and the calculations will be included in the report of the footing design. (Remember that if you alter the dimensions or loading you have to reevaluate Q_{uk}).

20 Base Plate design

Base plate bolt-connection is designed for the column over the concrete foundation. The anchor bolts are designed to resist shear and pullout forces due to uplift wind or seismic forces. CEN/TS 1992-4-1:1992 and CEN/TS 1992-4-2:1992 are used for the design of the fastenings in concrete. The connection is designed according to EN1993-1-8

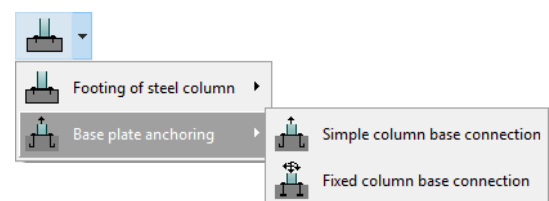

- Simple column base connection. Connection that resists only vertical and horizontal forces. Usual connection of Pin support of Portal frames.
- Fixed column base connection. Connection that resists vertical, horizontal forces and moments. Usual connection of Fixed support of Portal frames.

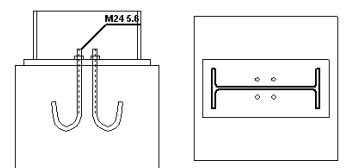

The connection has a base plate connected to the column by fillet welds. Holding down anchoring bolts are designed. The bolts are anchored in the concrete foundation with hooks or washer plates.

If the connection is simple connection then the connection is not designed to carry bending moment. (pin connection). In the case of pin connection the bolts are located in the middle of the column.
 If the connection is designed to carry bending moment (fixed connection), the bolts are located outside and close to the peripheral of the column.

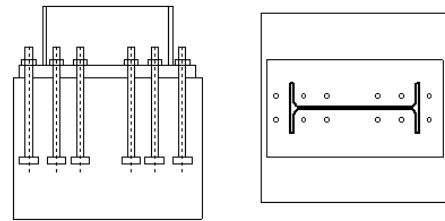

20.1 Loading

The final design actions, after multiplication of permanent and variable loading with safety factors (γ_G and γ_Q), Eurocode 0-19990-1-1, Tabl.A1.2. $N_{ed} = \gamma_G \cdot N_{gk} + \gamma_Q \cdot N_{qk}$.

$N(-)_{,ed}$ Axial load downwards.

$N(+),_{ed}$, Axial load upwards (uplift)

$V_{,ed}$ Horizontal shear force on the connection.

$M_{,ed}$ Moment.

For download loading usual values are $\gamma_G = 1.35$ (unfavourable), $\gamma_Q = 1.50$.

For uplift loading usual value are $\gamma_G = 0.90$ (favourable), $\gamma_Q = 0.00$.

20.2 Anchor type

The holding down *anchor bolts* of the base plate are extended with anchors into the foundation. The anchor system can be (simple hook, bended hook or washer plate). The holding down bolts are usually anchored into the foundation by bonding or by bonding and bearing. When there are moderate tension forces (usually in pin type connections) the anchor system can be with simple anchor hooks. The anchoring type with anchor hooks (first two choices) cannot be selected for bolt grade $f_y > 300 \text{ N/mm}^2$ ($M > 5.6$), according to Eurocode 1993-1-8:2005, 6.2.6.12 (6). Anchor bolts with hook have much lower capacity of anchors with washer plate. In case of very high tensile forces special anchor bolts must be provided.

If in the design process the base plate thickness or the anchor bolt diameter is not adequate the program adjust them (if possible) to new higher values if the boxes next to them are not checked.

20.3 Bearing capacity of concrete base

The partial loaded base area, develops local crushing and transverse forces. The bearing capacity is computed according to Eurocode 2 6.7. We assume (on the conservative side), that the maximum design distribution area has sides 50% more than the loaded area A_o , $A_{c1} = 1.50 \times 1.50 \times A_{co}$, $A_{c1}/A_{co} = 2.25$, $(A_{c1}/A_{co}) = 1.5$.

21 Short theoretical overview

21.1 Units

The units used in the program are **SI** (System International Metric) units. The unit of any input value is marked next to the place you enter the data. The unit of every value in the report is also marked.

- Units used in the program:
- length [m] . and [mm]
- forces [kN]
- moments [kNm]
- stresses [N/mm²] = [GPa]
- concentrated loads [kN]
- distributed loads [kN/m²]
- line loads [kN/m]

21.2 Coordinate system

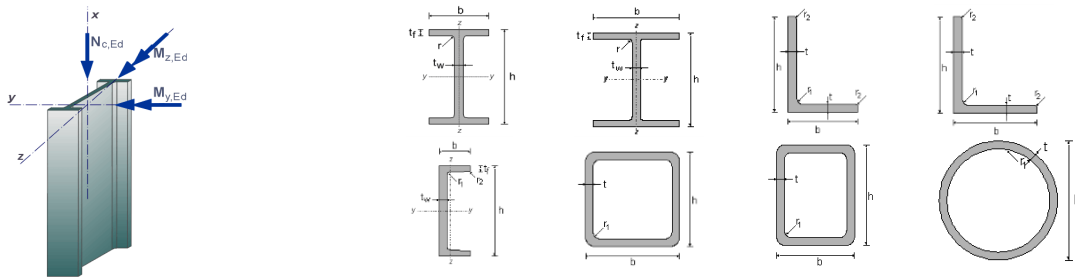

21.3 Design Loads, EN1991:2005 :

21.3.1 Permanent loads, EN1991-1:2005

Weight of structural elements.

21.3.2 Imposed loads EN1991-1:2005

A distributed imposed load qk according to Eurocode 1 EN1991-1-1 Tab 6.1 is considered on top of the roof.

21.3.3 Snow load EN1991-3:2003

Snow load is computed according to Eurocode 1-3 EN1991-3:2003, from the characteristic snow load on the ground and the roof slope.

$$s = \mu_i C_e C_t s_k \text{ (EN1991-3:2003 §5.2) [kN/m}^2\text{]}$$

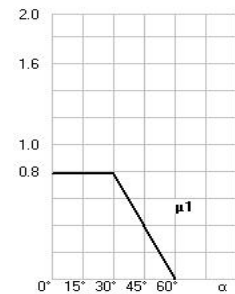

The three characteristic load arrangements of EN1991-3:2003 §5.3.3 are considered in the load cases. If the frame is flat ($\alpha=0^\circ$) one load arrangement is considered $s = 0.80 C_e C_t s_k$. The characteristic snow load on the ground s_k can be defined directly by selecting the snow region, snow zone and the altitude, according to EN1991-3:20 Annex C.

The snow load arrangements according to Eurocode 1-3 are
 Flat roofs. Load case (I)
 Pitched roofs Load cases (I) (II) III
 If the roof slop is low, only snow load arrangement (I) is necessary. The limit slope for this is angle $\alpha=2^\circ$. You can set this angle to a bigger value at Parameters/Design parameters/ parameters for Portal frames.

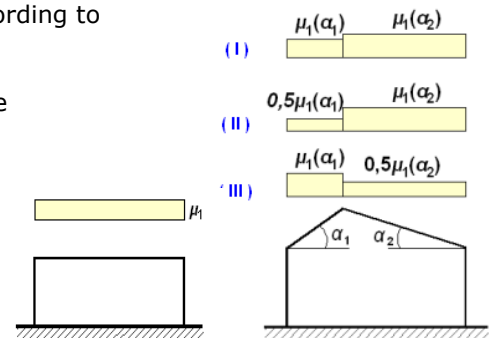

21.3.4 Wind load of EN1991-4:2005

Wind load is computed according to of EN1991-4:2005 §7.2.5 from the wind peak velocity pressure $q(z)$.

Wind pressure on surfaces $w_e = q(z) \cdot C_{pe}$ [kN/m²]

The wind pressure coefficients C_{pe} are computed from EN1991-4:2005 Tab.74a for roof surfaces and EN1991-4:2005 Tab 7.1 for the vertical wall surfaces.

The wind peak velocity pressure $q(z)$, can be defined directly from the wind velocity the terrain roughness and the oreography.

According to EN1991-4:2005 §4.5 and Annex A.

The wind pressure or under pressure on roof and wall surface are computed according to Eurocode 1-4. For roof slopes ($\alpha \leq 8^\circ$) one load arrangement is considered. For higher slope values two wind load cases are considered according to the pressure coefficients of Table 7.4a of Eurocode 1-4.

The specified internal pressure is always added (increase under pressure) to the external wind pressure situation.

21.3.5 Earthquake loading EN1998-1:2004

The earthquake loading is defined from the ground acceleration and the design spectrum according to Eurocode 8 EN1998-1:2004.

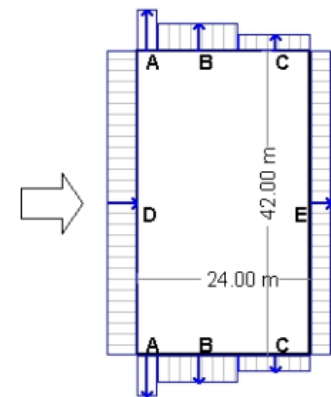
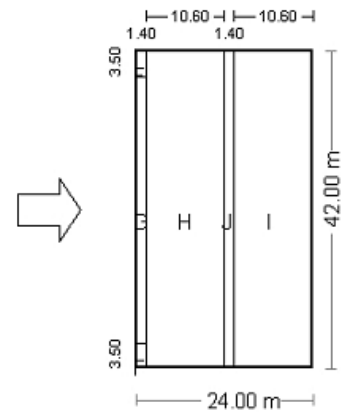

21.4 Design load combinations EN1990:2002

All the necessary load combinations defined in Eurocode0 EN1990:2002 are considered and the resulting design forces are checked in the strength verifications.

21.4.1 Load combination factors (EN1990 Tab.A1.1)

Category H (roofs)	$Q_k \psi_0=0.00, \psi_1=0.00, \psi_2=0.00$
Snow loads on buildings	$Q_s \psi_0=0.50, \psi_1=0.20, \psi_2=0.00$
Wind loads on buildings	$Q_w \psi_0=0.60, \psi_1=0.20, \psi_2=0.00$

21.4.2 Ultimate Limit State (ULS) (EQU)

$$E_d = \gamma_G \cdot G_k + \gamma_Q \cdot Q_{k1} + \gamma_Q \cdot \psi_0 \cdot Q_{k2} \quad (\text{Eq.6.10})$$

$\gamma_{G,\text{sup}}=1.10$ (Unfavourable)
 $\gamma_{G,\text{inf}}=0.90$ (Favourable)
 $\gamma_Q = 1.50$ (Unfavourable)
 $\gamma_Q = 0.00$ (Favourable)

21.4.3 Ultimate Limit State (ULS) (STR)

$$E_d = \gamma_G \cdot G_k + \gamma_Q \cdot Q_{k1} + \gamma_Q \cdot \psi_0 \cdot Q_{k2} \quad (\text{Eq.6.10})$$

$$E_d = \gamma_G \cdot G_k + \gamma_Q \cdot \psi_0 \cdot Q_{k1} + \gamma_Q \cdot \psi_0 \cdot Q_{k2} \quad (\text{Eq.6.10a})$$

$$E_d = \xi \cdot \gamma_G \cdot G_k + \gamma_Q \cdot Q_{k1} + \gamma_Q \cdot \psi_0 \cdot Q_{k2} \quad (\text{Eq.6.10b})$$

$\gamma_{G,\text{sup}}=1.35$ (Unfavourable)
 $\gamma_{G,\text{inf}}=1.00$ (Favourable)
 $\gamma_Q = 1.50$ (Unfavourable)
 $\gamma_Q = 0.00$ (Favourable)
 $\xi=0.850, \xi \cdot \gamma_G=0.850 \times 1.35=1.15$

21.4.4 Serviceability Limit State (SLS)

$$E_d = G_k + Q_{k1} + \psi_0 \cdot Q_{k2} + \psi_0 \cdot Q_{k3} \quad (\text{Characteristic combination}) \quad (\text{Eq.6.14b})$$

$$E_d = G_k + \psi_1 \cdot Q_{k1} + \psi_2 \cdot Q_{k2} + \psi_2 \cdot Q_{k3} \quad (\text{Frequent combination}) \quad (\text{Eq.6.15b})$$

$$E_d = G_k + \psi_2 \cdot Q_{k1} + \psi_2 \cdot Q_{k2} + \psi_2 \cdot Q_{k3} \quad (\text{Quasi-permanent combination}) \quad (\text{Eq.6.16b})$$

21.4.5 Ultimate Limit State (ULS) Seismic situation

$$E_d = G_k + A_{ed} + \psi_2 \cdot Q_{k1} + \psi_2 \cdot Q_{k2} + \psi_2 \cdot Q_{k3} \quad (\text{Eq.6.12b})$$

Snow load Q_s , Wind load Q_w , Seismic load A_{ed}

L.C. 601: $G_k + 0.30Q_{s1} + A_{ed}$ (Eq.6.14a)

21.5 Materials EN 1993-1-1:2005 § 3.2

The steel grades listed in Eurocode EN 1993-1-1 Table 3.1 and EN 1993-1-3 are included in the program.

The steel properties (yield strength f_y and ultimate strength f_u) can be changed from Parameters/Material.

Design values for: Modulus of elasticity $E=210000 \text{ N/mm}^2$, Poisson ratio $\nu=0.30$, Unit mass $\rho= 7850 \text{ Kg/m}^3$

21.5.1 Steel grades included in the program

S 235	EN 10025-2	$f_{y40}:235; f_{u40}:360$
S 275	EN 10025-2	$f_{y40}:275; f_{u40}:430$
S 355	EN 10025-2	$f_{y40}:355; f_{u40}:510$
S 450	EN 10025-2	$f_{y40}:440; f_{u40}:550$
S 275 N/NL	EN 10025-3	$f_{y400}:275; f_{u4}:390$
S 355 N/NL	EN 10025-3	$f_{y40}:355; f_{u40}:490$
S 420 N/NL	EN 10025-3	$f_{y40}:420; f_{u40}:520$



S 460 N/NL	EN 10025-3	fy40:460;fu40:540
S 275 M/ML	EN 10025-4	fy40:275;fu40:370
S 355 M/ML	EN 10025-4	fy40:355;fu40:470
S 420 M/ML	EN 10025-4	fy40:420;fu40:520
S 460 M/ML'	EN 10025-4	fy40:460;fu40:540
S 235 W	EN 10025-5	fy40:235;fu40:360
S 355 W	EN 10025-5	fy40:355;fu40:510
S 460 Q/QL	EN 10025-6	fy40:460;fu40:570
S 235 H	EN 10210-1	fy40:235;fu40:360
S 275 H	EN 10210-1	fy40:275;fu40:430
S 355 H	EN 10210-1	fy40:355;fu40:510
S 275 NH/NLH	EN 10210-1	fy40:275;fu40:390
S 355 NH/NLH	EN 10210-1	fy40:355;fu40:490
S 420 NH/NLH	EN 10210-1	fy40:420;fu40:540
S 460 NH/NLH	EN 10210-1	fy40:460;fu40:560
S 220GD+Z	EN 10147	fy40:220;fu40:300
S 250GD+Z	EN 10147	fy40:250;fu40:330
S 280GD+Z	EN 10147	fy40:280;fu40:360
S 320GD+Z	EN 10147	fy40:320;fu40:390
S 350GD+Z	EN 10147	fy40:350;fu40:420
H240LA	EN 10268	fy40:240;fu40:340
H280LA	EN 10268	fy40:280;fu40:370
H320LA	EN 10268	fy40:320;fu40:400
H360LA	EN 10268	fy40:360;fu40:430
H400LA	EN 10268	fy40:400;fu40:460
H260LAD	EN 10292	fy40:240;fu40:340
H300LAD	EN 10292	fy40:280;fu40:370
H340LAD	EN 10292	fy40:320;fu40:400
H380LAD	EN 10292	fy40:360;fu40:430
H420LAD	EN 10292	fy40:400;fu40:460
220GD+ZA	EN 10214	fy40:220;fu40:300
250GD+ZA	EN 10214	fy40:250;fu40:330
280GD+ZA	EN 10214	fy40:280;fu40:360
320GD+ZA	EN 10214	fy40:320;fu40:390
350GD+ZA	EN 10214	fy40:350;fu40:420

The steel grades for cold formed steel C Z and U sections are included.

21.6 Partial factors EN 1993-1-1:2005 § 6.1

The partial factors γ_M are applied to various characteristics resistance values. The partial factors are defined in the program from the selected National Annex., and can be overwritten in Parameters/National Annex parameters.

Usual values for steel structures

$$\gamma_{M0} = 1.00$$

$$\gamma_{M1} = 1.00$$

$$\gamma_{M2} = 1.25$$

Usual values for concrete structures (EN1992-1-1 Tab. 2.1N)

$$\gamma_c = 1.50 \text{ (concrete)}$$

$$\gamma_s = 1.15 \text{ (reinforcing steel)}$$

21.7 Second order effects EN1993-1-1 §5.2.1

The material behaviour is considered linear elastic. The second order effects are geometrical (P- Δ and P- δ) effects. The practical consequence of (P- Δ)-effects is to reduce the stiffness of the frame, with a result the increase of the deflections and the internal forces beyond the ones calculated from first-order analysis.

The effects of the deformed geometry are quantified using the factor a_{cr} EN1993-1-1 §5.2.1



$$\alpha_{cr} = F_{cr} / F_{ed} \quad \text{EN1993-1-1 Eq. (5.1)}$$

F_{ed}: is the design loading of the structure

F_{cr}: is the elastic critical buckling load for global instability mode based on initial elastic stiffness.

The frame is considered sufficiently stiff and second order effects may be ignored in a first order analysis if $\alpha_{cr} \geq 10$

For portal frames with shallow slopes according to EN1993-1-1 §5.2.1 (4) α_{cr} can be estimated as

$$\alpha_{cr} = \left(\frac{H_{Ed}}{V_{Ed}} \right) \left(\frac{h}{\delta_{H,Ed}} \right) \quad \text{EN1993-1-1 Eq (5.2)}$$

H_{ed} : total design the total design horizontal load

V_{ed} : total design vertical load

δ_{hed} : is the horizontal displacement at the top of the columns

h : is the column height

Axial force in the rafters may be assumed to be significant if

$$\bar{\lambda} < 0.5 \sqrt{\frac{A f_y}{N_{Ed}}} \quad \text{EN1993-1-1 Eq (5.3)}$$

According to EN1993-1-1 §5.2.2 (5), single story portal frames designed based on elastic analysis the global analysis second order effects due to vertical load may be calculated by increasing the horizontal loads H_{ed} by equivalent loads φ V_{ed} due to imperfections and other possible sway effects according to the first order theory by an amplification factor

$$\frac{1}{1 - \frac{1}{\alpha_{cr}}} \quad \text{provided that } \alpha_{cr} \geq 3 \quad \text{EN1993-1-1 Eq (5.4)}$$

If $\alpha_{cr} < 3$, second order analysis is necessary

21.8 Imperfections EN1993-1-1 §5.3.1

Global initial sway imperfection: $\varphi = \varphi_0 \cdot \alpha_h \cdot \varphi_m$



































































φ₀: Initial value = 1/200

α_h: Reduction factor for column height = 2/√h (2/3 ≤ α_h ≤ 1) (h: structure height)

φ_m: Reduction factor for number of columns in a row $\alpha_m = \sqrt{0.5(1 + \frac{1}{m})}$



21.9 Steel section types included in the program

<p> IPE</p> <ul style="list-style-type: none">  IPE Euronorm 19-57  IPE A  IPE D  IPE V  IPE 750 	<p> HE</p> <ul style="list-style-type: none">  HE A (IPB1) Euronorm 53-62  HE AA  HE B (IPB) Euronorm 53-62  HE M (IPBv) Euronorm 53-62  HE Euronorm 53-62  HL
<p> HD</p> <ul style="list-style-type: none">  HD-1  HD-2 ASTM A6/A 6M 	<p> W (ASTM)</p> <ul style="list-style-type: none">  W-1 ASTM A6/A 6M  W-2 ASTM A6/A 6M  W-3 ASTM A6/A 6M
<p> HP</p> <p> IPN</p>	
<p> UB, UC (BS)</p> <ul style="list-style-type: none">  UB-1 BS 4 part 1-1993  UB-2 BS 4 part 1-1993  UC BS 4 part 1-1993 	<p> ISMB, SC, HB</p> <ul style="list-style-type: none">  ISMB Indian Standard  ISSC Indian Standard  ISHB Indian Standard
<p> I GOST</p> <ul style="list-style-type: none">  No10..No60 GOST 8239-89  10B1..45B2 GOST 26020-83  50B1..100B4 GOST 26020-83  20SH1..70SH1 GOST 26020-83  20K1..40K5 GOST 26020-83  24DB1..50DH1 GOST 26020-83 <p>Russian standards</p>	<p> U</p> <ul style="list-style-type: none">  UPN  UAP NFA 45-255  UPE  5Y..40Y GOST 8240-89  5P..40P GOST 8240-89
<p> L</p> <ul style="list-style-type: none">  L20x20x3..80x80x8 Euronorm 56-77  L100x100x8..160x160x19 Euronorm 56-77  L180x180x16..250x250x28 Euronorm 56-77 	<p> La</p> <ul style="list-style-type: none">  L30x20x3..80x40x8 Euronorm 57-78  L90x60x6..130x40x12 Euronorm 57-78  L150x75x9..250x90x16 Euronorm 57-78
<p><input type="checkbox"/> hot rolled</p> <p><input type="checkbox"/> cold formed</p> <p> D= 10.2 – 1016 mm</p> <p> C</p> <ul style="list-style-type: none">  Steadman C140-C300  Ruukki C100-C350  Albion C125-Z226  Albion C246-Z401  Dimond DHS150-DHS400 	<p><input type="checkbox"/> hot rolled</p> <p><input type="checkbox"/> cold formed</p> <p> Z</p> <ul style="list-style-type: none">  Steadman Z140-Z300  Ruukki Z100-Z350  Albion Z125-Z226  Albion Z246-Z401  Metsec Z142-Z202  Metsec Z232-Z342  ICS Z152-Z254

21.10 Classification of cross sections EN 1993-1-1:2005 § 5.5

The design of steel elements can be done with elastic or plastic analysis depending on the class of the cross section.

The design of sections of classes 1 and 2 is based on the plastic resistance, the design of cross-sections of class 3 is based on elastic resistance, and the design of cross-sections of class 4 is based on elastic resistance and effective cross section properties.

The classification of cross sections in 1, 2, 3 and 4 classes depends on the ratios of thickness to width of the parts of the cross-section which are in compression according to tables 5.2 of EN 1993-1-1:2005.

Table 5.2 EN 1993-1-1:2005 – Internal compression parts

Internal compression parts						
						Axis of bending
						Axis of bending
Class	Part subject to bending	Part subject to compression		Part subject to bending and compression		
1						
	$c/t \leq 72\epsilon$	$c/t \leq 33\epsilon$		when $\alpha > 0,5$: $c/t \leq \frac{396\epsilon}{13\alpha - 1}$ when $\alpha \leq 0,5$: $c/t \leq \frac{36\epsilon}{\alpha}$		
2						
	$c/t \leq 83\epsilon$	$c/t \leq 38\epsilon$		when $\alpha > 0,5$: $c/t \leq \frac{456\epsilon}{13\alpha - 1}$ when $\alpha \leq 0,5$: $c/t \leq \frac{41,5\epsilon}{\alpha}$		
3						
	$c/t \leq 124\epsilon$	$c/t \leq 42\epsilon$		when $\psi > -1$: $c/t \leq \frac{42\epsilon}{0,67 + 0,33\psi}$ when $\psi \leq -1^{\circ}$: $c/t \leq 62\epsilon(1 - \psi)\sqrt{(-\psi)}$		
$\epsilon = \sqrt{235/f_y}$	f_y	235	275	355	420	460
	ϵ	1,00	0,92	0,81	0,75	0,71

Table 5.2 EN 1993-1-1:2005 – Outstanding flanges

Outstand flanges						
		Rolled sections		Welded sections		
Class	Part subject to compression	Part subject to bending and compression				
		Tip in compression		Tip in tension		
Stress distribution in parts (compression positive)						
1	$c/t \leq 9\epsilon$	$c/t \leq \frac{9\epsilon}{\alpha}$	$c/t \leq \frac{9\epsilon}{\alpha\sqrt{\alpha}}$			
2	$c/t \leq 10\epsilon$	$c/t \leq \frac{10\epsilon}{\alpha}$	$c/t \leq \frac{10\epsilon}{\alpha\sqrt{\alpha}}$			
Stress distribution in parts (compression positive)						
3	$c/t \leq 14\epsilon$	$c/t \leq 21\epsilon\sqrt{k_{\sigma}}$ For k_{σ} see EN 1993-1-5				
$\epsilon = \sqrt{235/f_y}$	f_y	235	275	355	420	460
	ϵ	1,00	0,92	0,81	0,75	0,71

Table 5.2 EN 1993-1-1:2005 - Angles

Angles						
Refer also to "Outstand flanges" (see sheet 2 of 3)					Does not apply to angles in continuous contact with other components	
Class	Section in compression					
Stress distribution across section (compression positive)						
3	$h/t \leq 15\epsilon; \frac{b+h}{2t} \leq 11,5\epsilon$					
Tubular sections						
Class	Section in bending and/or compression					
1	$d/t \leq 50\epsilon^2$					
2	$d/t \leq 70\epsilon^2$					
3	$d/t \leq 90\epsilon^2$					
NOTE For $d/t > 90\epsilon^2$ see EN 1993-1-6.						
$\epsilon = \sqrt{235/f_y}$	f_y	235	275	355	420	460
	ϵ	1,00	0,92	0,81	0,75	0,71
	ϵ^2	1,00	0,85	0,66	0,56	0,51



21.11 Ultimate limit states EN 1993-1-1:2005 § 6.2

21.11.1 Tension EN 1993-1-1:2005 § 6.2.3

$$\frac{N_{Ed}}{N_{t,Rd}} \leq 1 \quad (\text{EN 1993-1-1, 6.5})$$

Design plastic resistance of the cross-section.

$$N_{pl,Rd} = \frac{A \cdot f_y}{\gamma_{M0}} \quad (\text{EN 1993-1-1, 6.6})$$

Design ultimate resistance of net cross-section at holes for fasteners.

$$N_{u,Rd} = \frac{0.9A_{net} \cdot f_u}{\gamma_{M2}} \quad (\text{EN 1993-1-1, 6.7})$$

A area of cross-section

A_{net} area of net cross-section (minus holes)

f_y yield strength of steel

f_u ultimate strength of steel

γ_{M0} , γ_{M2} partial factors for material

21.11.2 Compression EN 1993-1-1:2005 § 6.2.4

$$\frac{N_{Ed}}{N_{c,Rd}} \leq 1 \quad (\text{EN 1993-1-1, 6.9})$$

$$N_{c,Rd} = \frac{A \cdot f_y}{\gamma_{M0}} \quad \text{for class 1, 2, 3 cross-sections} \quad (\text{EN 1993-1-1, 6.10})$$

$$N_{c,Rd} = \frac{A_{eff} \cdot f_y}{\gamma_{M0}} \quad \text{for class 4 cross-sections} \quad (\text{EN 1993-1-1, 6.11})$$

A area of cross-section

A_{eff} effective area of cross-section

f_y yield strength of steel

γ_{M0} partial factors for material

In case the design value of shear is $V_{Ed} > 0.50 V_{pl,Rd}$ the reduced yield strength is used.

$$(1 - \rho) f_y, \quad \text{where } \rho = \left(\frac{2V_{Ed}}{V_{pl,Rd}} - 1 \right)^2 \quad (\text{EN 1993-1-1, 6.29})$$



21.11.3 Bending moment EN 1993-1-1:2005 § 6.2.5

$$\frac{M_{Ed}}{M_{c,Rd}} \leq 1 \quad (\text{EN 1993-1-1, 6.12})$$

Design resistance of cross section for bending about the principal (y-y) or secondary (z-z) axis.

$$M_{y,Rd} = M_{pl,y,Rd} = \frac{W_{pl,y} \cdot fy}{\gamma_{M0}} \quad \text{for class 1, 2 cross-sections} \quad (\text{EN 1993-1-1, 6.13})$$

$$M_{z,Rd} = M_{pl,z,Rd} = \frac{W_{pl,z} \cdot fy}{\gamma_{M0}} \quad \text{for class 1, 2 cross-sections}$$

$$M_{y,Rd} = M_{el,y,Rd} = \frac{W_{el,y} \cdot fy}{\gamma_{M0}} \quad \text{for class 3 cross-sections} \quad (\text{EN 1993-1-1, 6.14})$$

$$M_{z,Rd} = M_{el,z,Rd} = \frac{W_{el,z} \cdot fy}{\gamma_{M0}} \quad \text{for class 3 cross-sections}$$

$$M_{y,Rd} = M_{c,y,Rd} = \frac{W_{eff,y} \cdot fy}{\gamma_{M0}} \quad \text{for class 4 cross-sections} \quad (\text{EN 1993-1-1, 6.15})$$

$$M_{z,Rd} = M_{c,z,Rd} = \frac{W_{eff,z} \cdot fy}{\gamma_{M0}} \quad \text{for class 4 cross-sections}$$

$W_{pl,y}$ $W_{pl,z}$ plastic section modulus about principal and secondary axis,

$W_{el,y}$ $W_{el,z}$ elastic section modulus about principal and secondary axis,

$W_{eff,y}$ $W_{eff,z}$ effective section modulus about principal and secondary axis,

fy yield strength of steel

γ_{M0} partial factors for material

When bending moment acts together with axial force design check is performed according to :

$$\frac{M_{Ed}}{M_{N,Rd}} \leq 1 \quad (\text{EN 1993-1-1, 6.31})$$

$$M_{N,Rd} = M_{pl,Rd} \left[1 - \left(\frac{N_{Ed}}{N_{pl,Rd}} \right)^2 \right] \quad (\text{EN 1993-1-1, 6.32})$$

In case the design value of shear is $V_{Ed} > 0.50V_{pl,Rd}$ the reduced yield strength is used.

$$(1 - \rho)fy, \quad \text{where } \rho = \left(\frac{2V_{Ed}}{V_{pl,Rd}} - 1 \right)^2 \quad (\text{EN 1993-1-1, 6.29})$$



21.11.4 Bi-axial bending EN 1993-1-1:2005 § 6.2.9

$$\left(\frac{M_{y,Ed}}{M_{y,Rd}}\right)^\alpha + \left(\frac{M_{z,Ed}}{M_{z,Rd}}\right)^\beta \leq 1 \quad (\text{EN 1993-1-1, 6.41})$$

For I and H sections: $\alpha=2, \beta=5n, \beta \geq 1$ ($n=N_{Ed}/N_{pl,Rd}$)
 For circular hollow sections: $\alpha=2, \beta=2$
 For rectangular hollow sections $\alpha=\beta=1.66/(1-1.13 n^2)$

21.11.5 Shear EN 1993-1-1:2005 § 6.2.6

$$\frac{V_{Ed}}{V_{c,Rd}} \leq 1 \quad (\text{EN 1993-1-1, 6.17})$$

Plastic shear resistance parallel to the cross-section web.

$$V_{z,Rd} = V_{pl,z,Rd} = \frac{A_{vz} \cdot f_y}{\sqrt{3}\gamma_{M0}} \quad (\text{EN 1993-1-1, 6.18})$$

Plastic shear resistance parallel to the cross-section flanges.

$$V_{y,Rd} = V_{pl,y,Rd} = \frac{A_{vy} \cdot f_y}{\sqrt{3}\gamma_{M0}} \quad (\text{EN 1993-1-1, 6.18})$$

A_{vy} A_{vz} shear areas parallel to the cross-section web or flanges,
 f_y yield strength of steel
 γ_{M0} partial factors for material

21.11.6 Buckling resistance of uniform members in compression

EN 1993-1-1:2005 § 6.3.1

Buckling resistance due to compression.

$$\frac{N_{Ed}}{N_{b,Rd}} \leq 1 \quad (\text{EN 1993-1-1, 6.46})$$

$$N_{b,Rd} = \frac{\chi A f_y}{\gamma_{M1}} \quad \text{for class 1, 2, 3 cross-sections} \quad (\text{EN 1993-1-1, 6.47})$$

$$N_{b,Rd} = \frac{\chi A_{eff} f_y}{\gamma_{M1}} \quad \text{for class 4 cross-sections} \quad (\text{EN 1993-1-1, 6.48})$$

The reduction factor χ is determined from the non-dimensional slenderness $\bar{\lambda}$

$$\chi = \frac{1}{\Phi + \sqrt{\Phi^2 - \bar{\lambda}^2}} \leq 1 \quad (\text{EN 1993-1-1, 6.49})$$

$$\Phi = 0.5 \left[1 + \alpha (\bar{\lambda} - 0.2) + \bar{\lambda}^2 \right]$$

$$\bar{\lambda} = \sqrt{\frac{A f_y}{N_{cr}}}; N_{cr} = \frac{\pi^2 E A}{\lambda^2}; \lambda = \frac{l_{eff}}{i}; i = \sqrt{\frac{I}{A}}$$

- $\bar{\lambda}$ non-dimensional slenderness,
- N_{cr} elastic critical buckling load,
- L_{cr} equivalent buckling length,
- λ slenderness,
- i radius of gyration.

The imperfection factor α that corresponds to the appropriate buckling curve a₀,a,b,c,d should be obtained from Table 6.2 of Eurocode 3, EN 1993-1-1:2005:

Buckling curve	a ₀	a	b	C	d
Imperfection factor α	0.13	0.21	0.34	0.49	0.76

Equivalent buckling lengths L_{cr}/L

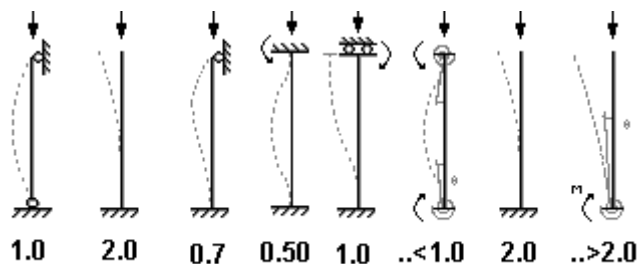
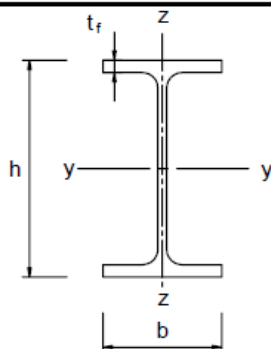
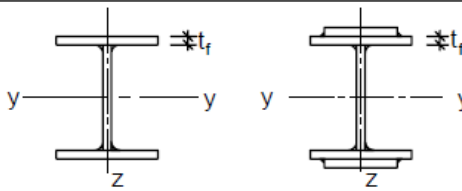

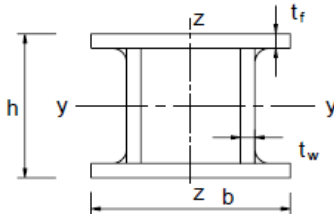
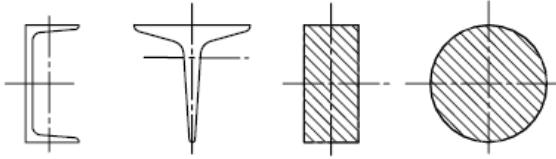
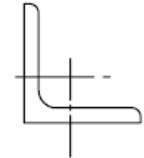

Table 6.2 EN 1993-1-1:2005 Selection of buckling curve of a cross-section

Cross section	Limits	Buckling about axis	Buckling curve		
			S 235 S 275 S 355 S 420	S 460	
Rolled sections 	$h/b > 1,2$	$t_f \leq 40 \text{ mm}$	y-y z-z	a b	a ₀ a ₀
		$40 \text{ mm} < t_f \leq 100$	y-y z-z	b c	a a
	$h/b \leq 1,2$	$t_f \leq 100 \text{ mm}$	y-y z-z	b c	a a
		$t_f > 100 \text{ mm}$	y-y z-z	d d	c c
Welded I-sections 	$t_f \leq 40 \text{ mm}$	y-y z-z	b c	b c	
	$t_f > 40 \text{ mm}$	y-y z-z	c d	c d	
Hollow sections 	hot finished	any	a	a ₀	
	cold formed	any	c	c	
Welded box sections 	generally (except as below)	any	b	b	
	thick welds: $a > 0,5t_f$ $b/t_f < 30$ $h/t_w < 30$	any	c	c	
U-, T- and solid sections 		any	c	c	
L-sections 		any	b	b	

**21.11.7 Lateral torsional buckling for uniform members
EN 1993-1-1:2005 § 6.3.2**

Lateral torsional buckling of uniform members in bending.

$$\frac{M_{Ed}}{M_{b,Rd}} \leq 1 \quad (\text{EN 1993-1-1, 6.54})$$

$$M_{b,Rd} = \frac{\chi_{LT} W_y f_y}{\gamma_{M1}} \quad (\text{EN 1993-1-1, 6.55})$$

$W_y = W_{pl,y}$ for class 1, 2 cross-sections,

$W_y = W_{el,y}$ for class 3 cross-sections,

$W_y = W_{eff,y}$ for class 4 cross-sections.

The reduction factor χ_{LT} is determined from the non-dimensional slenderness $\bar{\lambda}_{LT}$

$$\chi_{LT} = \frac{1}{\Phi_{LT} + \sqrt{\Phi_{LT}^2 - \bar{\lambda}_{LT}^2}} \leq 1 \quad (\text{EN 1993-1-1, 6.56})$$

$$\Phi_{LT} = 0.5 \left[1 + \alpha_{LT} (\bar{\lambda}_{LT} - 0.2) + \bar{\lambda}_{LT}^2 \right]$$

$$\bar{\lambda}_{LT} = \sqrt{\frac{W_y f_y}{M_{cr}}}$$

The imperfection factor α which corresponds to the appropriate buckling curve a,b,c,d:

Buckling curve	a	b	C	d
Imperfection factor α_{LT}	0.21	0.34	0.49	0.76

Recommended values for torsional buckling curves:

Rolled Sections $h/b < 2$ buckling curve a, $h/b > 2$ buckling curve b

Welded sections $h/b < 2$ buckling curve c, $h/b > 2$ buckling curve d

The critical elastic moment for lateral torsional buckling is computed according to Annex F of Eurocode 3-1-1 (1992).

$$M_{cr} = C_1 \frac{\pi^2 EI_z}{(kL)^2} \left[\sqrt{\left(\frac{k}{k_w} \right)^2 \frac{I_w}{I_z} + \frac{(kL)^2 GI_t}{\pi^2 EI_z} + (C_2 Z_g - C_3 Z_j)^2} - (C_2 Z_g - C_3 Z_j) \right]$$

C_1, C_2, C_3 , coefficients depending on the loading conditions and support conditions,
for a beam with uniform bending moment diagram $C_1=1.000, C_2=0.000, C_3=1.000$
for a beam with parabolic bending moment diagram $C_1=1.132, C_2=0.459, C_3=0.525$

I_t St. Venant torsional constant,

I_w warping constant,

I_z second moment of inertia about the weak axis,

L beam length between the support points,

k, k_w coefficients depending on the support conditions,

Z_g distance of shear center from point of load application



21.11.8 Uniform members in bending and compression EN 1993-1-1:2005 § 6.3.4

$$\frac{N_{Ed}}{\chi_y N_{Rk} / \gamma_{M1}} + k_{yy} \frac{M_{y,Ed}}{\chi_{LT} M_{y,Rk} / \gamma_{M1}} + k_{yz} \frac{M_{z,Ed}}{M_{z,Rk} / \gamma_{M1}} \leq 1 \quad (\text{EN 1993-1-1, 6.61})$$

$$\frac{N_{Ed}}{\chi_z N_{Rk} / \gamma_{M1}} + k_{zy} \frac{M_{y,Ed}}{\chi_{LT} M_{y,Rk} / \gamma_{M1}} + k_{zz} \frac{M_{z,Ed}}{M_{z,Rk} / \gamma_{M1}} \leq 1 \quad (\text{EN 1993-1-1, 6.62})$$

$$N_{Rk} = A f_y$$

$$M_{y,Rk} = W_{pl,y} f_y \text{ for class 1, 2 cross-sections}$$

$$M_{y,Rk} = W_{el,y} f_y \text{ for class 3 cross-sections,}$$

$$M_{y,Rk} = W_{eff,y} f_y \text{ for class 4 cross-sections,}$$

$$M_{z,Rk} = W_{pl,z} f_y \text{ for class 1, 2 cross-sections}$$

$$M_{z,Rk} = W_{el,z} f_y \text{ for class 3 cross-sections,}$$

$$M_{z,Rk} = W_{eff,z} f_y \text{ for class 4 cross-sections.}$$

The interaction coefficients $k_{yy}, k_{yz}, k_{zy}, k_{zz}$ are determined from tables B.1 and B.2

Table B.1 interaction coefficients $k_{yy}, k_{yz}, k_{zy}, k_{zz}$

Interaction factors	Type of sections	Design assumption	
		elastic cross-sectional properties class 3, class 4	plastic cross-sectional properties class 1, class 2
k_{yy}	I-sections RHS-sections	$C_{my} \left(1 + 0,6 \bar{\lambda}_y \frac{N_{Ed}}{\chi_y N_{Rk} / \gamma_{M1}} \right)$ $\leq C_{my} \left(1 + 0,6 \frac{N_{Ed}}{\chi_y N_{Rk} / \gamma_{M1}} \right)$	$C_{my} \left(1 + (\bar{\lambda}_y - 0,2) \frac{N_{Ed}}{\chi_y N_{Rk} / \gamma_{M1}} \right)$ $\leq C_{my} \left(1 + 0,8 \frac{N_{Ed}}{\chi_y N_{Rk} / \gamma_{M1}} \right)$
k_{yz}	I-sections RHS-sections	k_{zz}	$0,6 k_{zz}$
k_{zy}	I-sections RHS-sections	$0,8 k_{yy}$	$0,6 k_{yy}$
k_{zz}	I-sections	$C_{mz} \left(1 + 0,6 \bar{\lambda}_z \frac{N_{Ed}}{\chi_z N_{Rk} / \gamma_{M1}} \right)$ $\leq C_{mz} \left(1 + 0,6 \frac{N_{Ed}}{\chi_z N_{Rk} / \gamma_{M1}} \right)$	$C_{mz} \left(1 + (2\bar{\lambda}_z - 0,6) \frac{N_{Ed}}{\chi_z N_{Rk} / \gamma_{M1}} \right)$ $\leq C_{mz} \left(1 + 1,4 \frac{N_{Ed}}{\chi_z N_{Rk} / \gamma_{M1}} \right)$
	RHS-sections		$C_{mz} \left(1 + (\bar{\lambda}_z - 0,2) \frac{N_{Ed}}{\chi_z N_{Rk} / \gamma_{M1}} \right)$ $\leq C_{mz} \left(1 + 0,8 \frac{N_{Ed}}{\chi_z N_{Rk} / \gamma_{M1}} \right)$

For I- and H-sections and rectangular hollow sections under axial compression and uniaxial bending $M_{y,Ed}$ the coefficient k_{zy} may be $k_{zy} = 0$.

Table B.2

Interaction factors	Design assumptions	
	elastic cross-sectional properties class 3, class 4	plastic cross-sectional properties class 1, class 2
k_{yy}	k_{yy} from Table B.1	k_{yy} from Table B.1
k_{yz}	k_{yz} from Table B.1	k_{yz} from Table B.1
k_{zy}	$\left[1 - \frac{0,05\bar{\lambda}_z}{(C_{mLT} - 0,25)} \frac{N_{Ed}}{\chi_z N_{Rk} / \gamma_{M1}} \right]$ $\geq \left[1 - \frac{0,05}{(C_{mLT} - 0,25)} \frac{N_{Ed}}{\chi_z N_{Rk} / \gamma_{M1}} \right]$	$\left[1 - \frac{0,1\bar{\lambda}_z}{(C_{mLT} - 0,25)} \frac{N_{Ed}}{\chi_z N_{Rk} / \gamma_{M1}} \right]$ $\geq \left[1 - \frac{0,1}{(C_{mLT} - 0,25)} \frac{N_{Ed}}{\chi_z N_{Rk} / \gamma_{M1}} \right]$ <p>for $\bar{\lambda}_z < 0,4$:</p> $k_{zy} = 0,6 + \bar{\lambda}_z \leq 1 - \frac{0,1\bar{\lambda}_z}{(C_{mLT} - 0,25)} \frac{N_{Ed}}{\chi_z N_{Rk} / \gamma_{M1}}$
k_{zz}	k_{zz} from Table B.1	k_{zz} from Table B.1

Factor	Bending axis	Points braced in direction
C_{my}	y-y	z-z
C_{mz}	z-z	y-y
C_{mLT}	y-y	y-y

Table B.3

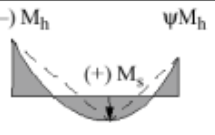
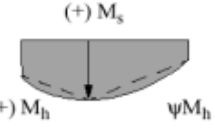
Moment Diagram	Range		C_{my}, C_{mz} и C_{mLT} under loading	
			Distributed	Concentrated
	$-1 \leq \psi \leq 1$		$0,6 + 0,4 \psi \geq 0,4$	
 $\alpha_s = M_s / M_h$	$0 \leq \alpha_s \leq 1$	$-1 \leq \psi \leq 1$	$0,2 + 0,8 \alpha_s \geq 0,4$	$0,2 + 0,8 \alpha_s \geq 0,4$
	$-1 \leq \alpha_s < 0$	$0 \leq \psi \leq 1$	$0,1 - 0,8 \alpha_s \geq 0,4$	$-0,8 \alpha_s \geq 0,4$
$-1 \leq \psi < 0$		$0,1(1 - \psi) - 0,8 \alpha_s \geq 0,4$	$0,2(-\psi) - 0,8 \alpha_s \geq 0,4$	
 $\alpha_h = M_h / M_s$	$0 \leq \alpha_h \leq 1$	$-1 \leq \psi \leq 1$	$0,95 + 0,05 \alpha_h$	$0,90 + 0,10 \alpha_h$
	$-1 \leq \alpha_h < 0$	$0 \leq \psi \leq 1$	$0,95 + 0,05 \alpha_h$	$0,90 + 0,10 \alpha_h$
$-1 \leq \psi < 0$		$0,95 + 0,05 \alpha_h(1 + 2\psi)$	$0,90 - 0,10 \alpha_h(1 + 2\psi)$	

22 Standards and Bibliography

EN 1990:2002/A1:2005/AC:2010

Eurocode - Basis of structural design

EN 1991-1-1:2002/AC:2009

Eurocode 1: Actions on structures - Part 1-1: General actions - Densities, self-weight, imposed loads for buildings

EN 1991-1-2:2002/AC:2013

Eurocode 1: Actions on structures - Part 1-2: General actions - Actions on structures exposed to fire

EN 1991-1-3:2003/AC:2009

Eurocode 1 - Actions on structures - Part 1-3: General actions - Snow loads

EN 1991-1-4:2005/A1:2010

Eurocode 1: Actions on structures - Part 1-4: General actions - Wind actions

EN 1991-1-4:2005/AC:2010

Eurocode 1: Actions on structures - Part 1-4: General actions - Wind actions

EN 1991-1-5:2003/AC:2009

Eurocode 1: Actions on structures - Part 1-5: General actions - Thermal actions

EN 1991-1-6:2005/AC:2013

Eurocode 1 - Actions on structures Part 1-6: General actions - Actions during execution

EN 1991-1-7:2006/AC:2010

Eurocode 1 - Actions on structures - Part 1-7: General actions - Accidental actions

EN 1991-2:2003/AC:2010

Eurocode 1: Actions on structures - Part 2: Traffic loads on bridges

EN 1991-3:2006/AC:2012

Eurocode 1 - Actions on structures - Part 3: Actions induced by cranes and machinery

EN 1991-4:2006/AC:2012

Eurocode 1 - Actions on structures - Part 4: Silos and tanks

EN 1992-1-1:2004

Eurocode 2: Design of concrete structures - Part 1-1: General rules and rules for buildings

EN 1992-1-1:2004/AC:2010

Eurocode 2: Design of concrete structures - Part 1-1: General rules and rules for buildings

EN 1992-1-2:2004/AC:2008

Eurocode 2: Design of concrete structures - Part 1-2: General rules - Structural fire design

EN 1992-2:2005/AC:2008

Eurocode 2 - Design of concrete structures - Concrete bridges - Design and detailing rules

EN 1992-3:2006

Eurocode 2 - Design of concrete structures - Part 3: Liquid retaining and containment structures

EN 1993-1-1:2005/AC:2009

Eurocode 3: Design of steel structures - Part 1-1: General rules and rules for buildings

EN 1993-1-2:2005/AC:2009

Eurocode 3: Design of steel structures - Part 1-2: General rules - Structural fire design

EN 1993-1-3:2006/AC:2009

Eurocode 3 - Design of steel structures - Part 1-3: General rules - Supplementary rules for cold-formed members and sheeting

EN 1993-1-4:2006

Eurocode 3 - Design of steel structures - Part 1-4: General rules - Supplementary rules for stainless steels

EN 1993-1-5:2006/AC:2009

Eurocode 3 - Design of steel structures - Part 1-5: Plated structural elements

EN 1993-1-6:2007/AC:2009

Eurocode 3 - Design of steel structures - Part 1-6: Strength and Stability of Shell Structures

EN 1993-1-7:2007/AC:2009

Eurocode 3 - Design of steel structures - Part 1-7: Plated structures subject to out of plane loading

EN 1993-1-8:2005/AC:2009

Eurocode 3: Design of steel structures - Part 1-8: Design of joints

EN 1993-1-9:2005/AC:2009

Eurocode 3: Design of steel structures - Part 1-9: Fatigue



EN 1993-1-10:2005/AC:2009

Eurocode 3: Design of steel structures - Part 1-10: Material toughness and through-thickness properties

EN 1993-1-11:2006/AC:2009

Eurocode 3 - Design of steel structures - Part 1-11: Design of structures with tension components

EN 1993-1-12:2007/AC:2009

Eurocode 3 - Design of steel structures - Part 1-12: Additional rules for the extension of EN 1993 up to steel grades S 700

EN 1997-1:2004/AC:2009

Eurocode 7: Geotechnical design - Part 1: General rules

EN 1997-2:2007/AC:2010

Eurocode 7 - Geotechnical design - Part 2: Ground investigation and testing

EN 1998-1:2004/A1:2013

Eurocode 8: Design of structures for earthquake resistance - Part 1: General rules, seismic actions and rules for buildings

EN 1998-1:2004/AC:2009

Eurocode 8: Design of structures for earthquake resistance - Part 1: General rules, seismic actions and rules for buildings.

EN 1998-2:2005/A1:2009

Eurocode 8: Design of structures for earthquake resistance - Part 2: Bridges

EN 1998-2:2005/A2:2011

Eurocode 8: Design of structures for earthquake resistance - Part 2: Bridges

EN 1998-2:2005/AC:2010

Eurocode 8 - Design of structures for earthquake resistance - Part 2: Bridges

EN 1998-3:2005/AC:2013

Eurocode 8: Design of structures for earthquake resistance - Part 3: Assessment and retrofitting of buildings

EN 1998-4:2006

Eurocode 8 - Design of structures for earthquake resistance - Part 4: Silos, tanks and pipelines

EN 1998-5:2004

Eurocode 8: Design of structures for earthquake resistance Part 5: Foundations, retaining structures and geotechnical aspects

EN 1998-6:2005

Eurocode 8: Design of structures for earthquake resistance - Part 6: Towers, masts and chimneys

Other Standard references**CEN/TS 1992-4-1:2009**

Design of fastenings for use in concrete - Part 4-1: General

CEN/TS 1992-4-2:2009

Design of fastenings for use in concrete - Part 4-2: Headed Fasteners

CEN/TS 1992-4-3:2009

Design of fastenings for use in concrete - Part 4-3: Anchor channels

CEN/TS 1992-4-4:2009

Design of fastenings for use in concrete - Part 4-4: Post-installed fasteners - Mechanical systems

CEN/TS 1992-4-5:2009

Design of fastenings for use in concrete - Part 4-5: Post-installed fasteners - Chemical systems

EN 13391:2004

Mechanical tests for post-tensioning systems

Other Bibliography

- Timoshenko, S.P. and Gere, J.M. *Theory of Elastic Stability*, Mc-Graw-Hill, 1961.
- Lawrence M. *Structural Design to Steelwork to EN1993 and EN1994*, Elsevier 2008
- Trahair NS, Branford MA, Nethercot DA, Gardner L, *The behaviour and Design of Steel Structures to EC3*, Taylor and Francis 2008
- Access Steel documents.
- Steel Construction Institute publications.

